

Specification	
Fluid	
Max.Press.	MPa
Max.Temp.	
Expansion Amt.	+ 10, - 25 mm

11	Guide Pipe	Carbon Steel Tube	ガイドパイプ	STK	1
10	Shipping Bolt	Rolled Steel	SHIPPINGボルト	SS400	3set
9	Shipping Washer	Rolled mild Steel	SHIPPING座金	SPHC	3
8	Ring	Rolled Steel	リング	SS400	1
7	Inside Pipe	Stainless Steel	内筒	SUS316L	1
6	Outside Pipe	Rolled mild Steel	外筒	SPHC	1
5	Bellows	Stainless Steel	ベローズ	SUS316L	1
4	Ring	Rolled Steel	リング	SS400	1
3	Guide Pipe	Carbon Steel Tube	ガイドパイプ	STK	1
2	Flange	Rolled Steel	フランジ	SS400	2
1	Packing Seat	Stainless Steel	パッキンシート	SUS316L	2
No.	Name of Parts	Material	部品名	材質	Q.TY

Shipping座金、Shippingボルトは、配管(固定点及びガイド施工)後取り外しの事。  
 Be sure to remove the Shipping Washer and Shipping Bolt after installation(Fixing point and guide execution).  
 (mm)

Size	L	使用最大長さ Max.operating Length	使用最小長さ Min.operating Length	最大伸縮長さ Max.Expansion Length	Do	Flange JIS 10K FF					Weight (kg)
						D	C	G	t	n-h	
20A	365	375	340	35	58.2	100	75	56	14	4-15	2.6
25A	365	375	340	35	58.2	125	90	67	14	4-19	3.3
32A	365	375	340	35	73.2	135	100	76	16	4-19	4.8
40A	365	375	340	35	73.2	140	105	81	16	4-19	5.0
50A	365	375	340	35	98.2	155	120	96	16	4-19	5.7
65A	415	425	390	35	109.7	175	140	116	18	4-19	8.9
80A	415	425	390	35	135.7	185	150	126	18	8-19	10.1
100A	415	425	390	35	161.7	210	175	151	18	8-19	10.1

TYPE EB-1J EXPANSION JOINT  
 伸縮管継手

Approval	M. Kume
Check	H. Tange
Drawing	T. Shinjo
Drawing No.	Y-0088-6005
Date	29 OCT. 2004

**Yoshitake**  
 INC.

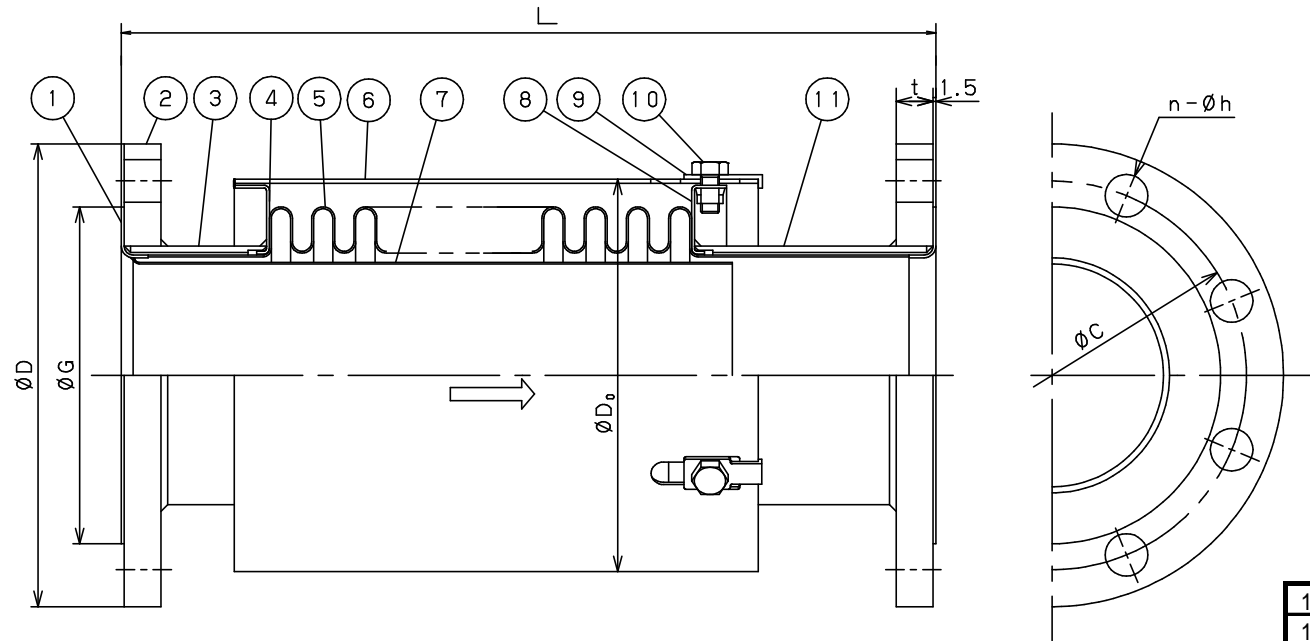

Specification	
Fluid	
Max. Press.	MPa
Max. Temp.	
Expansion Amt.	+ 10, - 25 mm

11	Guide Pipe	Carbon Steel	ガイドパイプ	STK	1
10	Shipping Bolt	Rolled Steel	SHIPPINGボルト	SS400	3set
9	Shipping Washer	Rolled mild Steel	SHIPPING座金	SPHC	3
8	Ring	Rolled Steel	リング	SS400	1
7	Inside Pipe	Stainless Steel	内筒	SUS316L	1
6	Outside Pipe	Rolled mild Steel	外筒	SPHC	1
5	Bellows	Stainless Steel	ベローズ	SUS316L	1
4	Ring	Rolled Steel	リング	SS400	1
3	Guide Pipe	Carbon Steel	ガイドパイプ	STK	1
2	Flange	Rolled Steel	フランジ	SS400	2
1	Packing Seat	Stainless Steel	パッキンシート	SUS316L	2
No.	Name of Parts	Material	部品名	材質	Q.TY

SHIPPING座金、 SHIPPINGボルトは、配管(固定点及びガイド施工)後取り外しの事。

Be sure to remove the Shipping Washer and Shipping Bolt after installation(Fixing point and guide execution). (mm)

Size	L	使用最大長さ Max.operating Length	使用最小長さ Min.operating Length	最大伸縮長さ Max.Expansion Length	Do	Flange JIS 10K FF					Weight (kg)
						D	C	G	t	n-h	
125A	440	450	415	35	212.1	250	210	182	20	8-23	21.0
150A	440	450	415	35	235.1	280	240	212	22	8-23	26.3

TYPE EB-1J EXPANSION  
JOINT  
伸縮管継手

Approval	M. Kume
Check	H. Tange
Drawing	T. Shinjo
Drawing No.	Y-0088-6005
Date	30 OCT. 2004

**Yoshitake**  
INC.

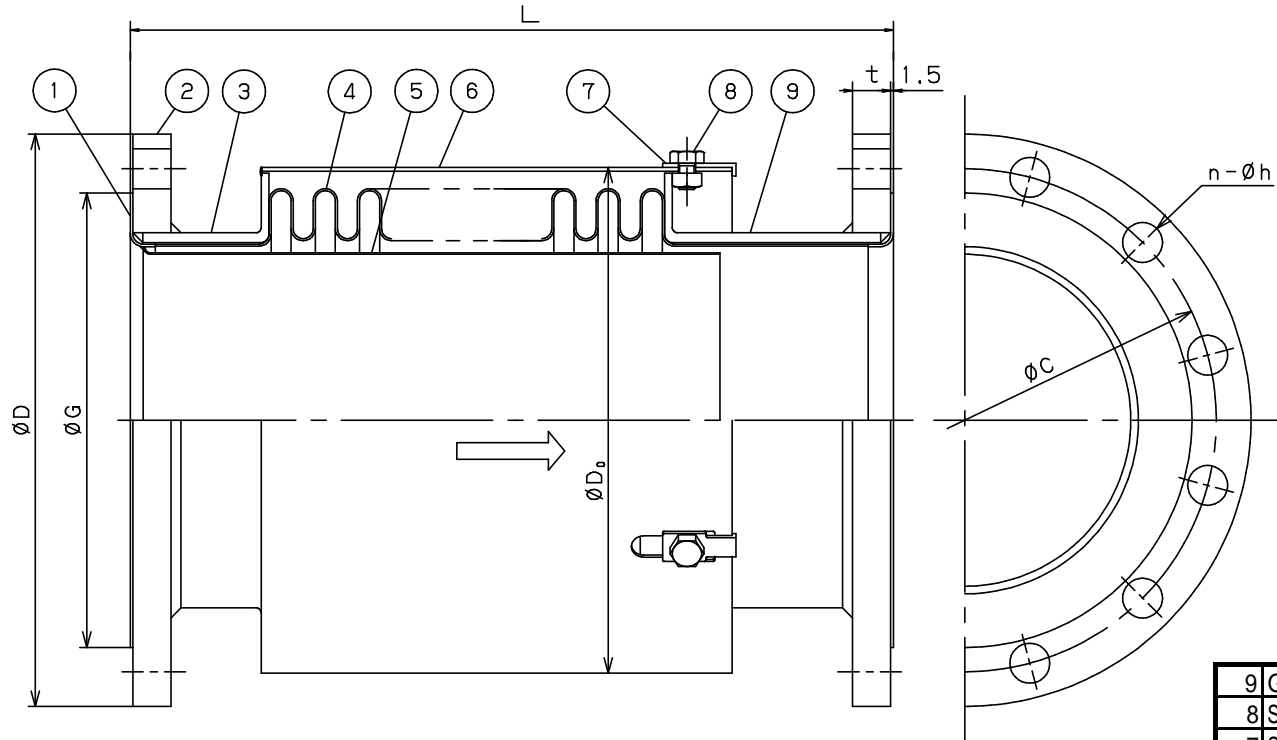

Specification	
Fluid	
Max. Press.	MPa
Max. Temp.	
Expansion Amt.	+ 10, - 25 mm

9	Guide Pipe	Carbon Steel Pipe	ガイドパイプ	SGP	1
8	Shipping Bolt	Rolled Steel	SHIPPING ボルト	SS400	3set
7	Shipping Washer	Rolled Steel	SHIPPING 座金	SS400	3
6	Outside Pipe	Rolled Steel	外筒	SS400	1
5	Inside Pipe	Stainless Steel	内筒	SUS316L	1
4	Bellows	Stainless Steel	ベローズ	SUS316L	1
3	Guide Pipe	Carbon Steel Pipe	ガイドパイプ	SGP	1
2	Flange	Rolled Steel	フランジ	SS400	2
1	Packing Seat	Stainless Steel	パッキンシート	SUS316L	2
No.	Name of Parts	Material	部品名	材質	Q.TY

Shipping 座金、Shipping ボルトは、配管(固定点及びガイド施工)後取り外しの事。

Be sure to remove the Shipping Washer and Shipping Bolt after installation(Fixing point and guide execution).  
(mm)

Size	L	使用最大長さ Max.operating Length	使用最小長さ Min.operating Length	最大伸縮長さ Max.Expansion Length	Do	Flange JIS 10K FF					Weight (kg)
						D	C	G	t	n-h	
200A	440	450	415	35	291.6	330	290	262	22	12-23	35.3
250A	465	475	440	35	332.6	400	355	324	24	12-25	52.5

## TYPE EB-1J EXPANSION JOINT 伸縮管継手

Approval	M. Kume
Check	H. Tange
Drawing	T. Shinjo
Drawing No.	Y-0088-6005
Date	31 OCT. 2004

**Yoshitake**  
INC.