

- 付属品  
 ・ケーブルコネクタ (ナイロン製) , G 1/2, 適合ケーブル 6~12∅  
 ・プラグ

No	Name of Parts	Material	部品名	材質	Q. TY
9	Actuator	Aluminium	電動操作機	ADC	1
8	Conector	Cast Stainless Steel	コネクタ	SCS13A	1
7	Conector	Stainless Steel	コネクタ	SUS303 or SUS304	1
6	Bracket	Cast Steel	ブラケット	SCPH2	1
5	Packing	PTFE	パッキン	PTFE	1
4	Stem	Stainless Steel	ステム	SUS304	1
3	Seat	PTFE	シート	PTFE	2
2	Ball	Stainless Steel or Cast Stainless Steel	ボール	SUS304 or SCS13A	1
1	Body	Ductile Cast Iron	本体	FCD400	1

\*製品に流れ方向の制約はありません。

Size	L	L <sub>1</sub>	H	d	D	C	t	n-h	Weight (kg)	Actuator
65A	190	87	368	64	175	140	18	4-19	22	AD1-700
80A	203	97	400	76	185	150	18	8-19	26	HD1-02K
100A	229	116	436	102	210	175	18	8-19	37	HD1-02K

Specification	
Fluid	
Press.	MPa
Temp.	℃
Rate Voltage	AC100/110V 50/60Hz共通 AC200/220V 50/60Hz共通

TYPE MD-55 TWO WAY  
 電動二方弁 MOTOR VALVE

Approval	T. Watanabe
Check	K. Yasuda
Drawing	Y. Morita
Drawing No.	Y-852-9406-1D
Date	21 OCT. 2021



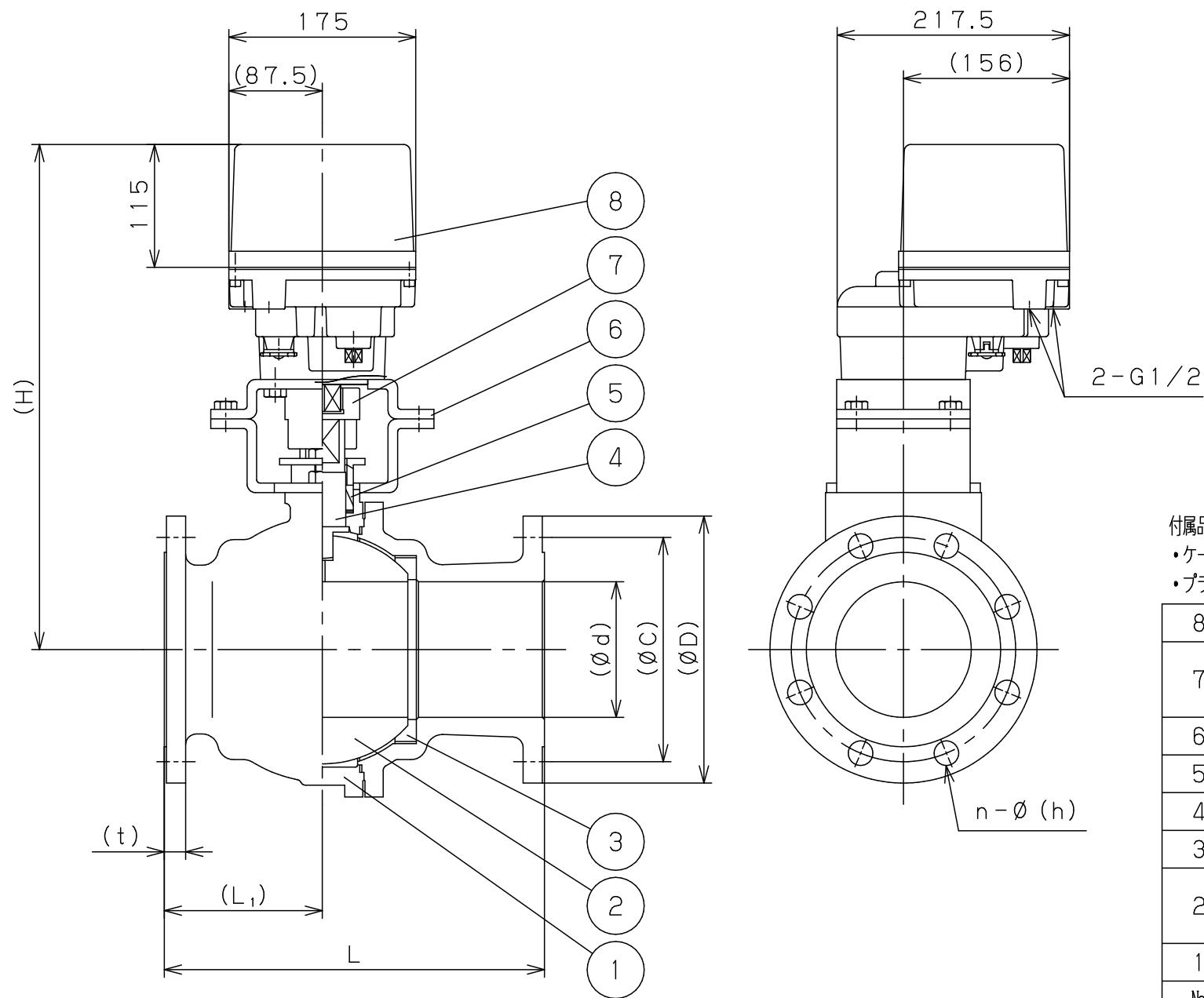

付属品

- ケーブルコネクタ (ナイロン製), G 1/2, 適合ケーブル ∅6~12
- プラグ

No.	Name of Parts	Material	部品名	材質	Q. TY
8	Actuator	Aluminium	電動操作機	ADC	1
7	Conector	Stainless Steel	コネクタ	SUS303 or SUS304	1
6	Bracket	Rolled Steel	ブラケット	SS400	1
5	Packing	PTFE	パッキン	PTFE	1
4	Stem	Stainless Steel	ステム	SUS304	1
3	Seat	PTFE	シート	PTFE	2
2	Ball	Stainless Steel or Cast Stainless Steel	ボール	SUS304 or SCS13A	1
1	Body	Ductile Cast Iron	本体	FCD400	1

\*製品に流れ方向の制約はありません。

Size	L	L <sub>1</sub>	H	d	D	C	t	n-h	Weight (kg)	Actuator
125A	356	148	473	127	250	210	20	8-23	68	HD1-06K
150A	394	173	493	152	280	240	22	8-23	88	HD1-06K

Specification	
Fluid	
Press.	MPa
Temp.	℃
Rate Voltage	AC100/110V 50/60Hz共通 AC200/220V 50/60Hz共通

TYPE MD-55 TWO WAY  
電動二方弁 MOTOR VALVE

Approval	T. Watanabe
Check	K. Yasuda
Drawing	Y. Morita
Drawing No.	Y-852-9406-2D
Date	21 OCT. 2021

