

TYPE SY—20

STRAINER

Installation & Operation Manual

We thank you very much for using the Yoshitake Products. In order to put in use our product correctly and safely, please make sure to read this manual thoroughly prior to the installation. Also we kindly request you to keep this manual with care at your hand.

————— The following safety symbols are used in this manual. —————

⚠ Warning

Indicates that mishandling this product might cause fatal or serious bodily injury.

⚠ Caution

Indicates that mishandling this product might cause bodily injury or material damage.

Table of Contents

1. Overview	1
2. Specifications	1
3. Dimensions and Weights	1
4. Operation	2
5. Pressure loss	
5.1. Strainer of diameter	3
5.2. Selection of pipe diameter	3
5.3. Pressure loss diagram	4
6. Installation	
6.1. Example of piping	5
6.2. Precautions during installation and inspection	5
7. Operating Procedure	
7.1. Precautions during operation and inspection	6
8. Maintenance Procedure	
8.1. Troubleshooting	7
8.2. Precautions during maintenance and inspection	7
8.3. Disassembly Procedure	7
8.4. Assembly Procedure	8
8.5. Assembly	8
8.6. Exploded drawing	8

YOSHITAKE

1. Overview

Used in wide range of purpose as dust removing from water and oil. Mainly used for cooling water and water for industrial use.

2. Specifications

Type		SY-20-10	SY-20-20
Connection		JIS 10K RF	JIS 20K RF
Nominal Size		15A~150A	
Application		Steam・Air・Cold and hot water・Oil・Other non-dangerous fluids	
Maximum Pressure		1.0MPa	2.0MPa
Maximum Temperature		260°C	
Material	Body	SCPH2	
	Screen	SUS304	
Screen	Perforated plate	φ6 - 8P	
	Element	80 mesh	

・20~60Mesh Screen are also available.

⚠ Caution

- (1) Please collate with attached nameplate and specification of ordered model.
 ※Please consult factory in case they do not match each other.

3. Dimensions and Weights

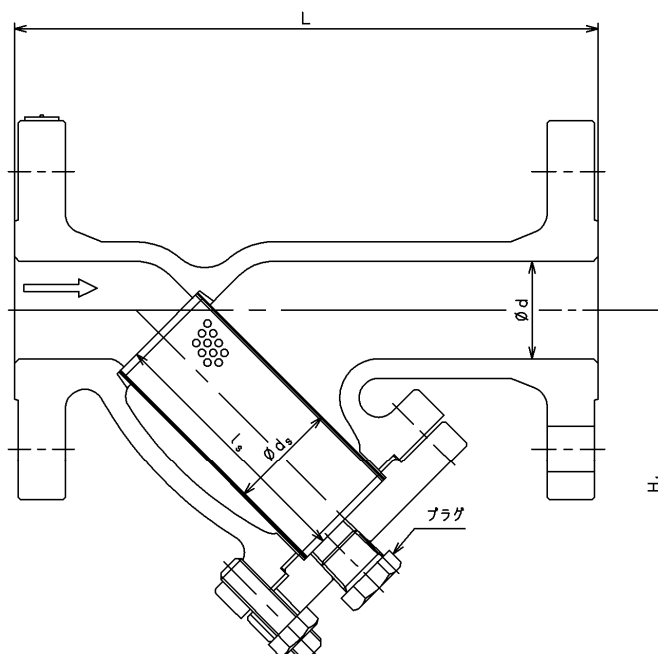

SY-20-10 (mm)

Size	L	H ₁	Screen		d	Plug	Weight (kg)
			ds	ls			
15A	160	104	25	65.5	15	R 3/8	3.0
20A	160	113	30	71.5	20	R 3/8	3.7
25A	180	122	33	76.0	25	R 3/8	4.8
32A	240	154	55	105.0	40	R 1/2	8.0
40A	240	154	55	105.0	40	R 1/2	8.0
50A	260	174	57	112.0	50	R 1/2	10.5
65A	275	187	74	130.0	65	R 1/2	14.3
80A	290	241	90	163.0	80	R 3/4	18.3
100A	362	280	114	187.0	100	R 3/4	34.2
125A	420	330	140	224.5	125	R 3/4	46.3
150A	520	386	184	308.5	150	R 3/4	75.1

SY-20-20 (mm)

Size	L	H ₁	Screen		d	Plug	Weight (kg)
			ds	ls			
15A	160	104	25	56.5	15	R 3/8	3.2
20A	160	113	30	67.5	20	R 3/8	4.0
25A	180	122	33	75.0	25	R 3/8	5.9
32A	240	154	55	101.0	40	R 1/2	9.3
40A	240	154	55	101.0	40	R 1/2	9.3
50A	260	174	57	114.5	50	R 1/2	13.0
65A	275	187	74	124.0	65	R 1/2	15.8
80A	360	241	90	167.0	80	R 3/4	28.0
100A	362	280	114	187.0	100	R 3/4	37.8
125A	415	330	140	224.5	125	R 3/4	57.0
150A	520	386	184	308.5	150	R 3/4	82.8

4.Operation

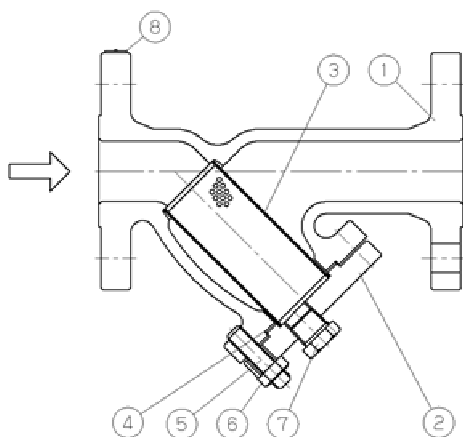

No.	Name of Parts
1	Body
2	Cover
3	Screen
4	Gasket
5	Stud Bolt
6	Nut
7	Plug
8	Name Plate

The screen③ removes dust, scale and other foreign matter out of the fluid flow from inlet port of strainer.

5. Pressure loss

To use the strainer most effectively and to fulfill the required criteria thoroughly, please take the following points into consideration.

5.1 Selection of strainer diameter

The same one as the piping size is selected (piping size = strainer size) if a small size is used, pressure drop grows and pressure prescribed at the entrance of the equipment might not be able to be maintained.

5.2 Selection of pipe diameter

When selecting the nominal diameter of pipe, it is necessary to consider the kind of fluid, its maximum flow rate, allowable pressure loss and piping installation cost among others. Smaller diameter of pipe makes the lower piping cost, but the pressure loss will be increased and there are possibilities of abrasion of pipe, noise and vibration due to turbulent flow. If the pipe diameter is too large, not only the piping cost but also the heat loss will be increased.

As one method of selection of suitable pipe diameter, Japan Industrial Standard (JIS) sets the standard flow velocity depends on the relative kind of fluid, its characteristic and pipe diameter, to which please refer.

«Standard flow velocity of fluid»

Fluid	Standard flow velocity
Water ,Oil	2 m/s(2~4)
Steam	30 m/s(20~40)

※ This list shows the standard flow velocity of relative fluid, which made in reference with the standard of JIS F7101 (Ship's Machinery Standard Flow Velocity in Pipes).

5.3 Pressure loss diagram (Fluid Water)

Screen: Perforated plate ϕ 6.0-8P Element 80mesh

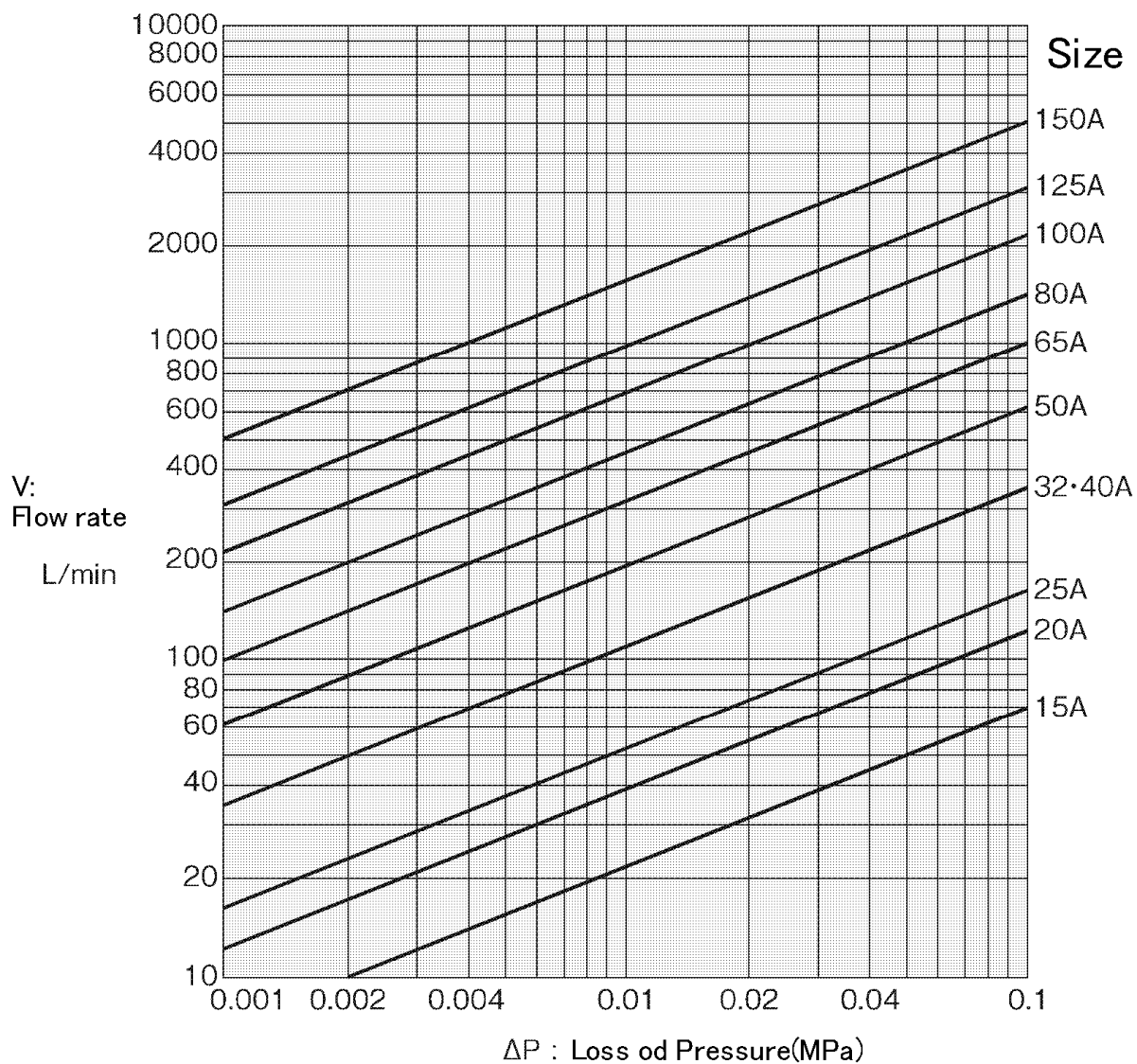

6. Installation

6.1 Example of piping

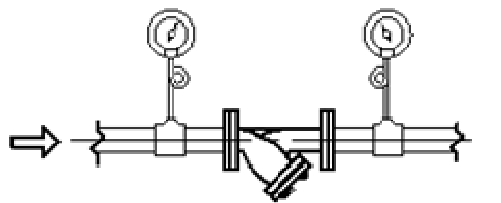

Figure-1

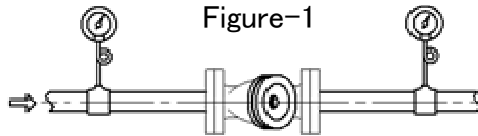

Figure-2

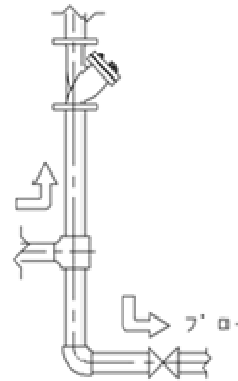

Figure-3

6.2 Precautions during installation and inspection

⚠ Warning

- (1) Because of heavy weight, hold the valve with lifting equipment while piping. Refer to “3. Dimensions and weights” table for the valve weight.
※ Failure to do so may result in injury due to dropping the valve.

⚠ Caution

- (1) When installing, confirm if the direction of fluid flow matches with inlet and outlet port of the product respectively.
※ If installed in opposite direction, it will not function as designed.
 - (2) Carry out the securing of pipes and the product properly.
※ Excessive piping stress may cause the deformation of strainer.
 - (3) When installing, reserve the space shown in Figure-4 for the maintenance and checking (cleaning of the screen).
※ It will be impossible to carry out the maintenance and inspection (cleaning of the screen).
 - (4) Do not apply excessive load, torque or vibration to the valve.
※ The fluid may leak from strainer.
 - (5) Carry out the connection with pipes properly.
※ Improper piping connection may cause the leakage of fluid due to vibration or other cause. With some kind of fluid, there will be a danger of personnel being scalded.
※ The fluid flowed out of pipe end may cause some material damages.
- (1) In case installing pressure gauge at backward and forward of strainer, clogging can be checked by differential pressure. [Ref.6.1. Example of piping figure 1]
 - (2) Install strainer with the cap parts facing downward. [Ref.6.1. Example of piping figure 1] However, install strainer with cap parts facing sideways in case of steam piping so that condensate accumulation is minimized. [Ref.6.1. Example of piping figure 2]
 - (3) If fluid flows from bottom to top, install a blow valve in order to remove scale accumulated at the bottom of riser pipe. [Ref.6.1. Example of piping figure 3]

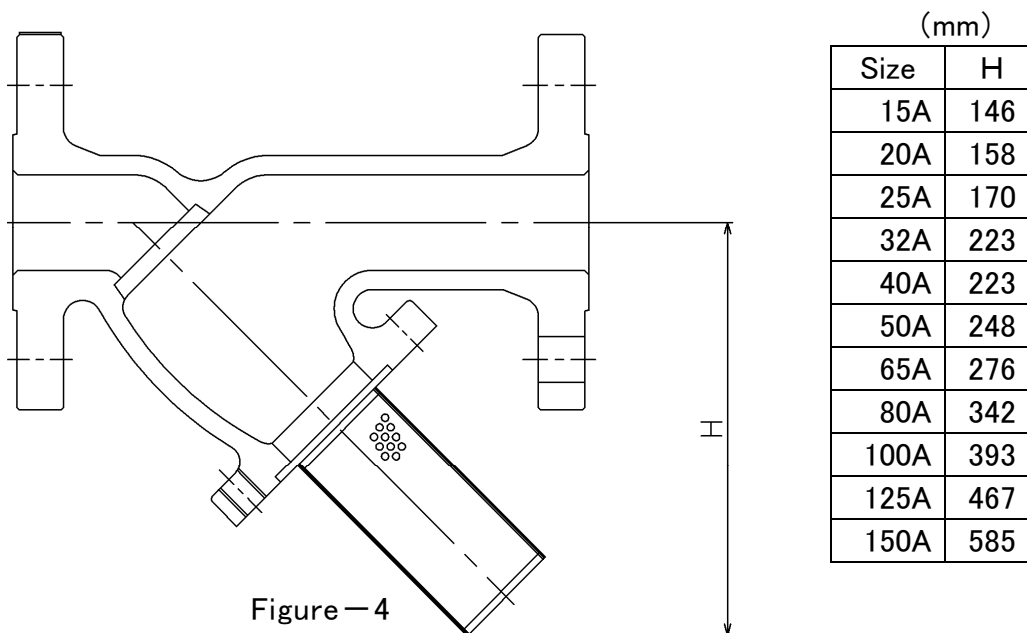

Figure — 4

7. Operating Procedure

7.1 Precautions during operation and inspection

⌚ Warning

- (1) Prior to letting the fluid run in the system, make sure that there is no danger when the fluid flows out of pipe end.
- ※ In case the fluid of high temperature flows out of pipe end, there will be a danger of personnel being scalded.
 - ※ The fluid flowed out of pipe end may cause some material damages.
- (2) Do not tighten the cap and the cover after flowing the fluids to the valve.
- ※ The gasket will be broken and leads to have a leakage.

⌚ Caution

- (1) Use the strainer in condition of maximum pressure loss of below 0.1MPa. Also keep cleaning the screen periodically.
- ※ The screen may be damaged.

8. Maintenance Procedure

8.1 Troubleshooting

Trouble condition	Cause of trouble	Countermeasure and remedy
No fluid flows.	1. Screen③ is clogged up. 2. Stop valves at inlet and/or outlet side are shut.	1. Disassemble and clean the screen③. 2. Open stops valves.
Pressure loss is excessive.	1. Screen③ is clogged up. 2. Pressure gauge is damaged.	1. Disassemble and clean the screen③. 2. Renew the Pressure gauge
Outer leakage accure	1. Gasket have deterioration.	1. Replace the gasket.

8.2 Precautions during maintenance and inspection

⚠ Warning

- (1) Completely discharge internal pressure from the strainer, lines, and equipment, and cool the strainer down to a level where you can touch it with bare hands before disassembly and inspection.
✘ Failure to do so may result in injury or burns due to residual pressure or spillage around the product.
- (2) In case the high temperature of fluid is applied, keep the bare hand off the strainer.
✘ It may cause the personnel being scalded.
- (3) Since the screen is heavy in weight, when extracting the screen from the body, make sure to secure it properly with lifting devices.
✘ The screen fallen down may cause the injury.

8.3 Disassembly Procedure

- (1) After confirming that the remaining pressure is relieved from the strainer, remove the bolts⑥ from the cover② and the gasket④, and remove the cover② from the body①. Extract the screen③ from the body① and clean it with compressed air or cleanser.

8.4 Assembly Procedure

⚠ Caution

- (1) When re-assembling, fix the relative parts properly.
 ※Parts may be deformed or damaged.
- (2) Tighten the bolts evenly on each bolt in turn of diagonal position.
 ※The fluid may leak from strainer. If the fluid is of high temperature, the leakage may cause being scalded.

(1) When tighten the nut⑥, Please confirm That apical part of stud bolt⑤ will Come out from flange and nut⑥.

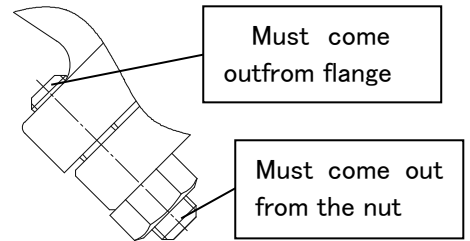

8.5 Assembly

Clean the gasket contacting surface of the body① and cap② and fit a new gasket④ to the cap fit the screen③ to the body① and the Cap② before tightening the nut.

8.6 Exploded drawing

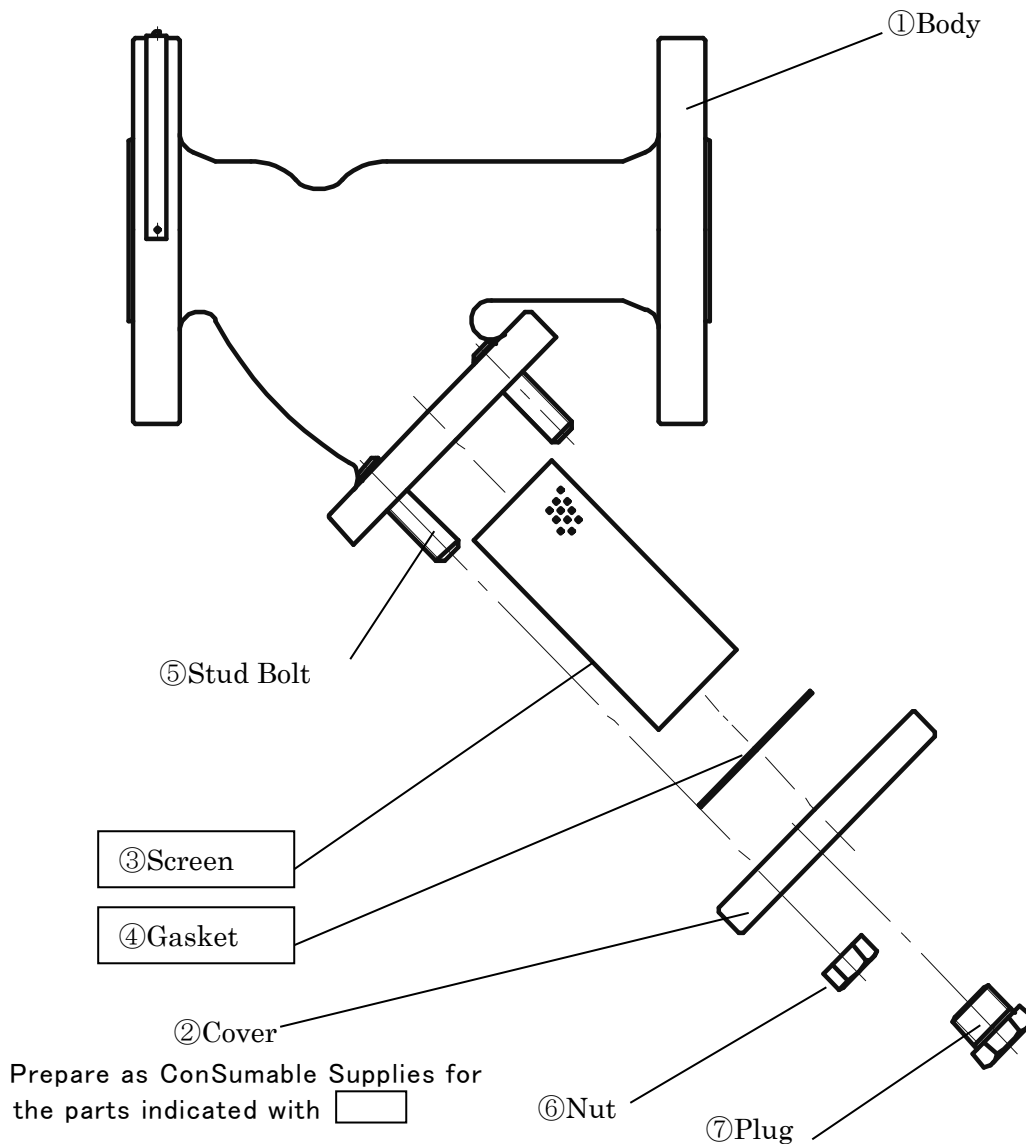

Warranty Information

1. Limited warranty

This product has been manufactured using highly-advanced techniques and subjected to strict quality control. Please be sure to use the product in accordance with instructions on the manual and the label attached to it.

Yoshitake warrants the product to be free from any defects in material and workmanship under normal usage for a period of one year from the date of receipt by the original user, but no longer than 24 months from the date of shipment from Yoshitake's factory.

2. Parts supply after product discontinuation

This product may be subject to discontinuation or change for improvement without any prior notice. After the discontinuation of the product, Yoshitake supplies the repair parts for 5 years otherwise individually agreed.

3. This warranty does not cover the damage due to any of below:

- (1) Valve seat leakage or malfunction caused by foreign substances inside piping.
- (2) Improper handling or misuse.
- (3) Improper supply conditions such as abnormal water pressure/quality.
- (4) Water scale or freezing.
- (5) Trouble with power/air supply.
- (6) Any alteration made by other than Yoshitake.
- (7) Use under severe conditions deviating from the design specifications (e.g. in case of corrosion due to outdoor use).
- (8) Fire, flood, earthquake, thunder and other natural disasters.
- (9) Consumable parts such as O-ring, gasket, diaphragm and etc.

Yoshitake is not liable for any damage or loss caused by malfunction or defect of the product.