



# MODEL SY-6, SY-6-N, SY-6L, SY-6L-N STRAINER

## PRODUCT MANUAL

Thank you very much for choosing the Yoshitake's product. To ensure the correct and safe use of the product, please read this manual before use. This manual shall be kept with care for future references.

The symbols used in this manual have the following meanings.

	<b>Warning</b>	This symbol indicates a potentially hazardous situation that, if not avoided, could result in death or serious injury.
	<b>Caution</b>	This symbol indicates a hazardous situation that, if not avoided, may result in minor or moderate injury or may result in only property damage.

---

### Table of Contents

---

Usage of the Product .....	1
1. Features .....	1
2. Specifications.....	1
3. Dimensions and Weight .....	2
4. Nominal Size Selection .....	3
4.1 Selection of nominal size.....	3
4.2 Selection of nominal pipe size .....	3
4.3 Nominal size selection chart.....	4
5. Installation .....	5
5.1 Piping example .....	6
6. Operation .....	7
7. Maintenance .....	8
7.1 Troubleshooting .....	8
7.2 Disassembly .....	8
7.3 Reassembly .....	8
8. Warranty Information .....	9



## Usage of the Product

The product is widely used for dust removal in various types of pipelines. Especially, a strainer shall be installed upstream of pressure reducing valves, temperature regulating valves, solenoid valves or trap valves to protect and maintain them.

### 1. Features

1. The product is compact and lightweight, and offers outstanding economic efficiency.
2. The product is a high-flow marine type with as large a filtration area as possible in order to avoid clogging and consequent problems such as flow rate drop.
3. The product is made of bronze and offers outstanding corrosion resistance.  
[SY-6L and SY-6L-N]
4. Corrosive portions, such as the end faces of lining steel piping and the threads, are isolated from the fluid by a pipe end core and a sealing agent for rust prevention.
5. The pipe end core isolates the junction of two different metals from contact with water and thus prevents corrosion on metal parts induced by the potential difference between these metals.
6. The product does not require any piping joints such as bronze nipples and corrosion-resistant sockets, ensuring easy plumbing and cost reduction.
7. Since an integral core is built-in, failure to insert a core no longer occurs.
8. The core has an O-ring structure and maintains a high degree of air-tightness.

### 2. Specifications

Model		SY-6	SY-6-N	SY-6L	SY-6L-N
Type		For general piping		Common core	
Application		Steam, air, cold and hot water, oil and other non-dangerous fluids	Cold and hot water	Cold and hot water	
Max. pressure		1.3MPa		1.0MPa	
Max. temperature		220°C	80°C	40°C	
Material	Body	Cast bronze	Cast bronze (NPb-treated)	Cast bronze	Cast bronze (NPb-treated)
	Screen	Stainless steel			
Screen	Perforations	φ2.5-7.21 holes/cm <sup>2</sup>			
	Mesh	Standard 80 mesh	Standard 60 mesh		
Connection		JIS Rc screwed			

- The products with 20 to 100 mesh filter are also available upon request.
- SY-6-N and SY-6L-N comply with the Water Works Law of Japan.



#### Caution

If you need strict elimination of foreign substances, please contact us.  
\*Foreign substances equal to or smaller than the mesh size may not be completely caught due to the structure of the product.

### 3. Dimensions and Weight

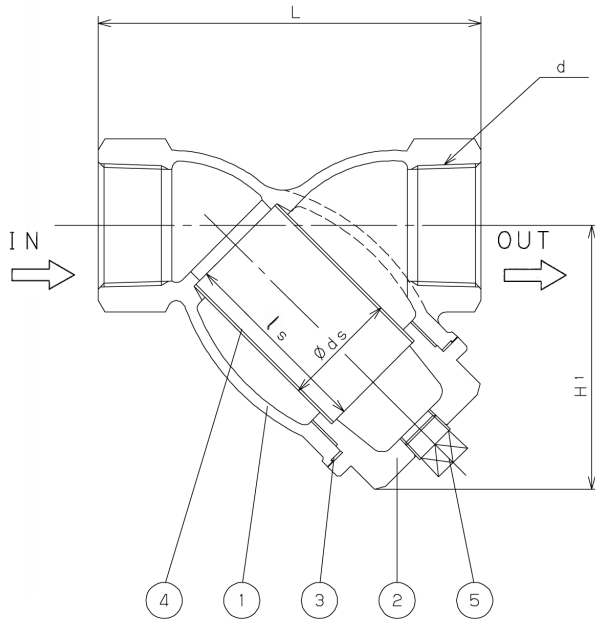

SY-6 and SY-6-N 40A-50A

No.	Part name
1	Body
2	Cap
3	Gasket
4	Screen
5	Plug
6	Core

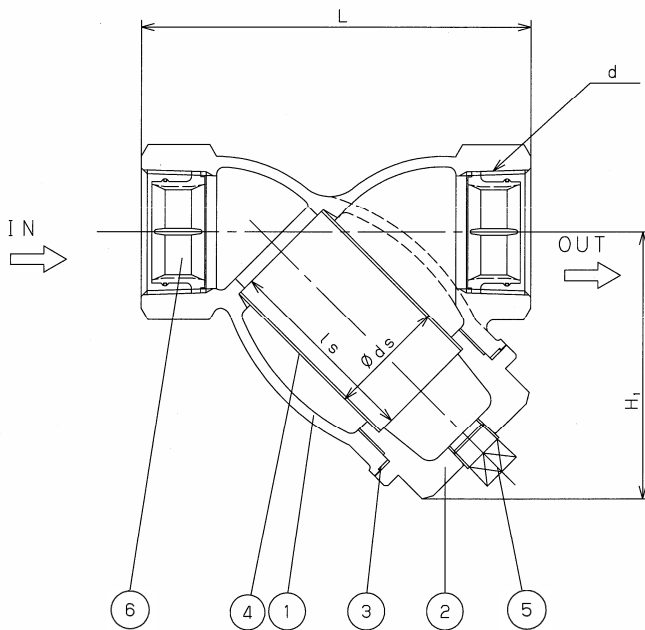

SY-6L and SY-6L-N 40A-50A

Nominal size	[mm]					
	d	L	H <sub>1</sub>	ds	ls	Connection
15A	Rc1/2	86	55	20	35	(R 1/4)
20A	Rc3/4	98	70	25	50	(R 3/4)
25A	Rc 1	117	80	32	60	(R 3/8)
32A	Rc1 1/4	145	92	40	70	(R 3/8)
40A	Rc1 1/2	148	105	45	75	R 3/8
50A	Rc 2	178	122	56	90	R 3/8

Dust, scale and other foreign substances which flow into the strainer through the inlet port are removed by the screen [4].

## 4. Nominal Size Selection

To make the best use of the product and to satisfy the operating requirements to the maximum, take notice of the following. The preferred initial pressure loss is 0.02-0.03 MPa.

### 4.1 Selection of nominal size

Select a nominal size of the product equivalent to that of the pipe (nominal pipe size = nominal size of strainer). Note that use of a smaller nominal size increases the pressure loss through the strainer, and may possibly reduce the equipment inlet pressure below the specified limit.

### 4.2 Selection of nominal pipe size

When selecting an appropriate nominal pipe size, it is necessary to consider fluid type, maximum flow rate, permissible pressure loss, costs of piping and equipment, etc. If the nominal pipe size is smaller, the costs of piping and equipment decreases while the pressure loss through the pipe increases to generate disturbances, possibly resulting in pipe wear, noise and/or vibration. If the nominal pipe size is too large, not only the costs of piping and equipment but also the thermal loss increase. As a reference, the standard flow velocity is specified in the Japanese Industrial Standards (JIS) as a guide to select an appropriate nominal pipe size. See the following table.

<<Standard flow velocity>>

Fluid	Remarks	Standard flow velocity
Saturated steam	Auxiliary piping for vacuum or small-diameter piping	15 m/s [10-20]
	Large-diameter piping	30 m/s [20-40]
Superheated steam	Piping diameter: approx. $\phi 75 - \phi 250$	40 m/s [30-50]
	Piping of high-grade material	70 m/s [65-80]
Inlet of steam coil	0.3-0.7MPa	30 m/s [25-30]
Air	Higher pressure: 1.0 MPa or more	20 m/s [20-25]
	Lower pressure	15 m/s [5-15]
	Extremely low pressure: 0.1 MPa or less	10 m/s [3-10]
Water		2 m/s [2- 4]

\* This table is based on the requirements provided in JIS F 7101 [Shipbuilding – Pipes of machinery – Standard velocity of flow].

### 4.3 Nominal size selection chart [Fluid: Water]

Screen:  $\phi 2.5-7.21$  holes/cm<sup>2</sup> perforations with 60 mesh filter

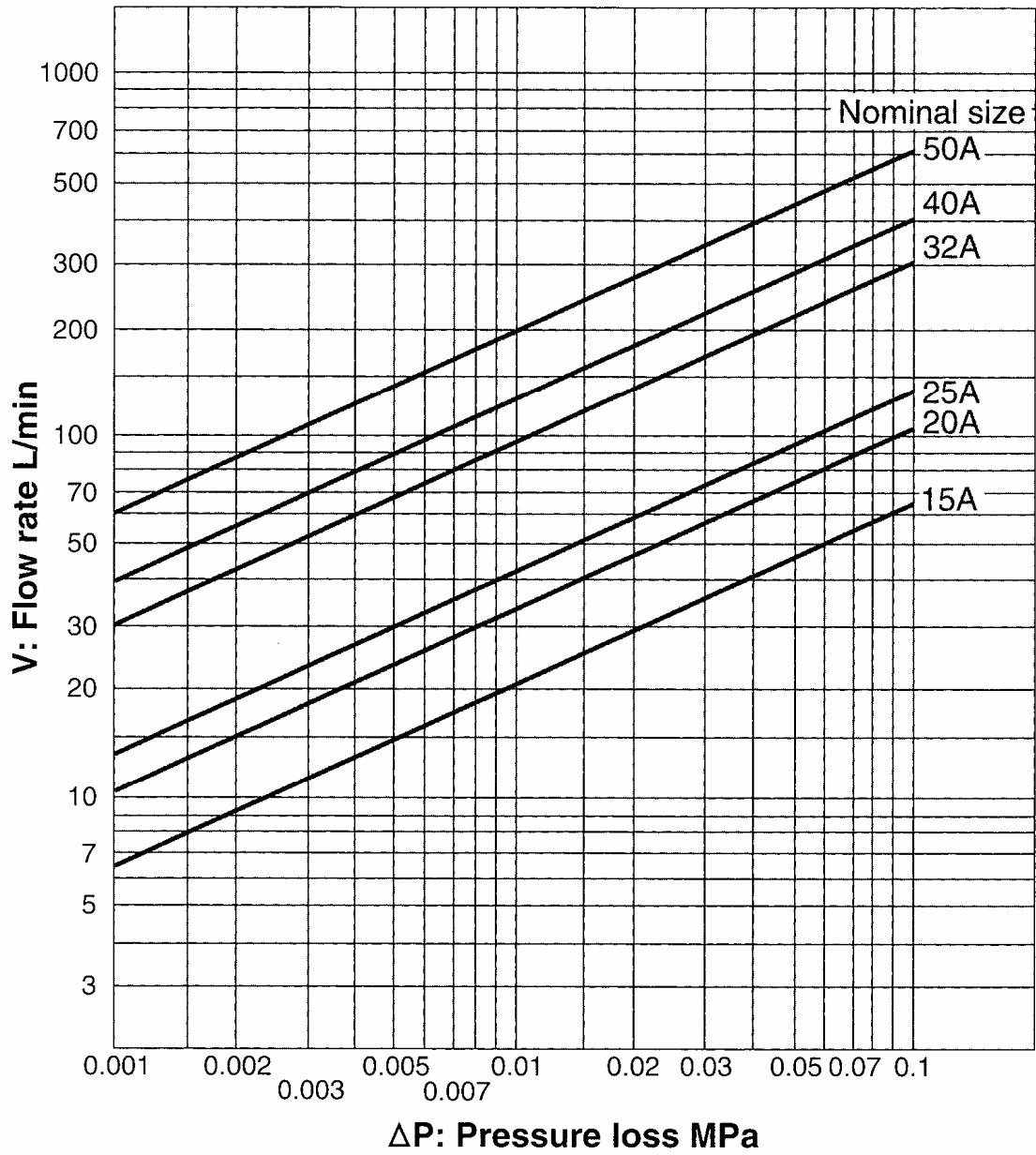

---

## 5. Installation

---



### Caution

1. When installing, check the direction of the product so that the fluid flowing and the arrow marked on the product are in the same direction.
    - \* Setting the product in wrong directions prevents the product from performing as intended.
  2. Make sure to support pipes and to secure the product with certainty.
    - \* If an excessive piping stress is applied, the product may be deformed.
  3. When installing, enable the operator to pick up the screen from the product by reserving a working space required for maintenance and inspection (cleaning of the screen).
    - \* Failure to reserve a working space prevents maintenance and inspection (cleaning of the screen).
  4. Connect the product to the pipes securely.
    - \* Improper connecting may cause fluid leakage from the pipes when vibration is applied to them.
  5. If you need strict elimination of foreign substances, please contact us.
    - \* Foreign substances equal to or smaller than the mesh size may not be completely caught due to the structure of the product.
- 〈SY-6L and SY-6L-N〉
6. The dedicated thread for the product is designed to have enough length to fasten the core to the body. Do not screw the core of the product into other valves or joints.
    - \* Failure to follow this instruction may result in damage on the core.
    - \* Use a strainer equipped with the core for lining steel piping.
  7. Keep the pipe end core away from fire, and do not expose it to high temperature at welding.
    - \* Fire or high temperature conditions may cause the core to deform, resulting in the product malfunction.
  8. The strainer equipped with the pipe end core shall be kept indoors. If it has to be kept outdoors inevitably, please avoid direct sunlight or rainwater.
  9. If the product is frozen, use an electric deicer, a steam deicer or warm water for deicing it.

## 5.1 Piping example

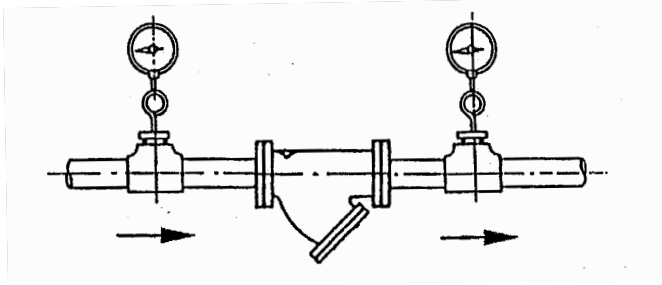

Fig. 1 Horizontal piping

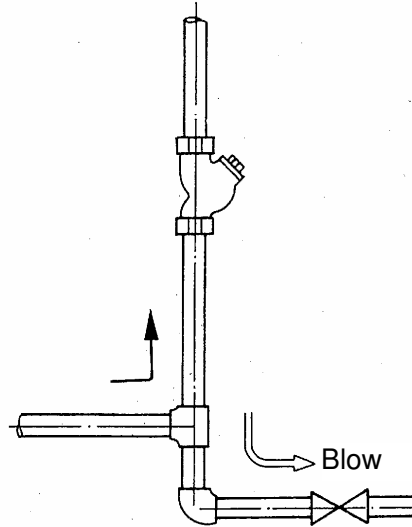

Fig. 2 Vertical piping

1. Clogging inside the product can be known from the differential pressure measured when pressure gauges are installed in upstream and downstream of the product. [See Fig. 1.]
2. The product shall be installed with its cap faced downward. If drainage or similar problem occurs in a steam line, incline the cap horizontally.
3. If the product can only be piped to run the fluid from the bottom to the top, make sure to install a blow valve in order to remove the scale accumulated at the bottom of the riser pipe. [See Fig. 2.]

■ Plumbing procedure for SY-6L and SY-6L-N

1. Checking the piping  
Use on-specification piping. Using off-specification piping may result in impairments of the core's corrosion-resistant function, such as incomplete air-tightness or a deformed core.
2. Cutting the piping  
Make sure to cut the piping perpendicularly to its axis.  
When cutting, use an automatic metal saw machine or automatic circular saw machine.  
Note) Do not use a pipe cutter, and do not make gas cutting, arc cutting, or high-speed wheel cutting. Additionally, do not fail to wipe off the oil attached to the piping.
3. Chamfering the piping  
Use a scraper or another chamfering tool to remove burrs from the inside surface of the piping briefly.
4. Threading the piping  
Cut threads that comply with the Japanese industrial standards (JIS). Thin threads of non-standard cause damage to the core. Check the threads with a thread gauge.
5. Applying a sealant  
Apply an anti-corrosive sealant uniformly to both the male threads and the ends of piping.
6. Joining the piping  
Refer to the standard number of threads screwed in and the standard screw-in length shown in the table below.

Nominal size	Std. number of threads screwed in	Std. screw-in length [mm]	Std. tightening torque [N·m]
15A	5.5	10	40
20A	6	11	60
25A	5.5	13	100
32A	6.5	15	120
40A	6.5	15	150
50A	8	18.5	200

---

## 6. Operation

---



### Warning

Before letting the fluid into the product, make sure that there is no possibility of danger when the fluid flows into the ends of piping.  
\* The hot fluid, if spouted out, may scald your skin.  
\* The fluid outflow may cause physical damage.



### Caution

Use the product with a maximum pressure loss below 0.1 MPa. Periodically clean the screen.  
\* The screen may be broken.

Clogging can be monitored when pressure gauges installed upstream and downstream of the strainer.



## 7. Maintenance

### **Warning**

1. When disassembling or inspecting, make certain that internal pressures have been completely released from the product and the piping.  
When the product is used for hot fluid, cool down the product to the condition that it can be touched with bare hands.  
\*Residual pressure or hot fluid may lead to scald or injury.
2. When the product is used for hot fluid, do not touch the product with bare hands.  
\* The product having hot fluid may scald your skin.
3. Clean the screen periodically.  
\* Failure to follow this notice may cause damage to the screen due to scale clogging.

### **Caution**

1. When reassembling, connect all parts securely.  
\* Failure to follow this notice may result in deformed or broken parts.
2. When reassembling, replace the gasket with a new one.  
\* Failure to follow this notice may result in fluid leakage, and may also scald your skin if the fluid is hot.

The numbers referred to in the following correspond with those in “3. Dimensions and Weight” on Page 2.

### 7.1 Troubleshooting

Trouble	Cause	Remedy
Fluid does not flow.	1. Screen [4] is clogged.	1. Disassemble the product and clean the screen [4].
	2. Stop valves in upstream and downstream are closed.	2. Open the stop valves.
Excessive pressure loss	1. Screen [4] is clogged.	1. Disassemble the product and clean the screen [4].
	2. Pressure gauge is out of order.	2. Replace the pressure gauge with a new one.
	3. Nominal size of the product is too small for the piping	3. Replace the product with a new one proper for the piping nominal size.

### 7.2 Disassembly

After checking that no pressure remains in the product, remove the cap [2] and the gasket [3].  
Remove the screen [4] from the body [1] and clean it with compressed air or detergent.

### 7.3 Reassembly

Clean the gasket space of both the body [1] and the cap [2]. In order to install the cleaned screen [4], set it and a new gasket [3] on the cap [2] and then enter them together into the body [1].

Gasket [3] and screen [4] are consumable supplies and available as replacements.