

Model TA-3 series

AIR VENT VALVE

Instruction Manual

Thank you very much for using the Yoshitake Products. In order to put in use our product correctly and safely, please make sure to read this manual thoroughly prior to the installation. Also we kindly request you to keep this manual with care at your hand.

The following safety symbols are used in this manual.

Warning

This symbol indicates a potentially hazardous situation that, if not avoided, could result in death or serious injury.

Caution

This symbol indicates a hazardous situation that, if not avoided, may result in minor or moderate injury. ("Caution" may also be used to indicate other unsafe practices or risks of property damage.)

Contents

1. Specifications and performances	1-3
2. Dimensions and Weights	3
3. Operation	4
4. Maintenance and inspection	
4.1 Caution before usage	5
4.2 Warning during operation	7
4.3 Troubleshooting	7
5. Disassembly	
5.1 Precautions during disassembly and inspection ..	8
5.2 Disassembly procedure	8
5.3 Assembly procedure	8
5.4 Caution for assembly	9
6. Exploded drawing	10
After Sales Service	

1. Specifications and Performances

Model		TA-3	TA-3C	TA-3C-N
Application		Cold and hot water, Oil (Specific gravity: 0.8 or more)		Cold and hot water
Working pressure		0.01 - 1.0MPa		
Max. temperature		90°C	60°C	
Material	Body, Cover	Cast iron (FCD450)		
	Valve	Brass		
	Valve seat	Brass (with NBR disc)		Brass (with FKM disc)
	Float	Stainless Steel		
Connection		JIS Rc screwed		

- TA-3 air vent valve is electrodeposition-coated for rustproofing.
- The maximum temperature in case of continuous usage is 90 degrees C. (TA-3C).
- Keep the valve warm in case of 40 degrees difference from atmospheric temperature (TA-3C and TA-3C-N).
- Coating: The body and cap are coated with nylon 11 (white) for both sides, outside and inside (TA-3C and TA-3C-N).
- TA-3C-N is compliant with waterworks law capacity standard.

Model	TA-6	
Application	Cold and hot water, Oil (Specific gravity: 0.8 or more)	
Working pressure	0.01~1.0MPa	
Max. temperature	90°C	
Material	Body, Cover	Cast bronze
	Valve	Brass
	Valve seat	Brass (with NBR disc)
	Float	Stainless Steel
Connection	JIS Rc screwed	



Caution

- (1) Please confirm that the indications on the product correspond with the specifications of the ordered product model before use.
- (2) Before using the product, verify the display contents of the nameplate attached to the product against the specification contents of the order type.

* If they are different, please contact us without using the product.

■ Exhaust Capacity Chart

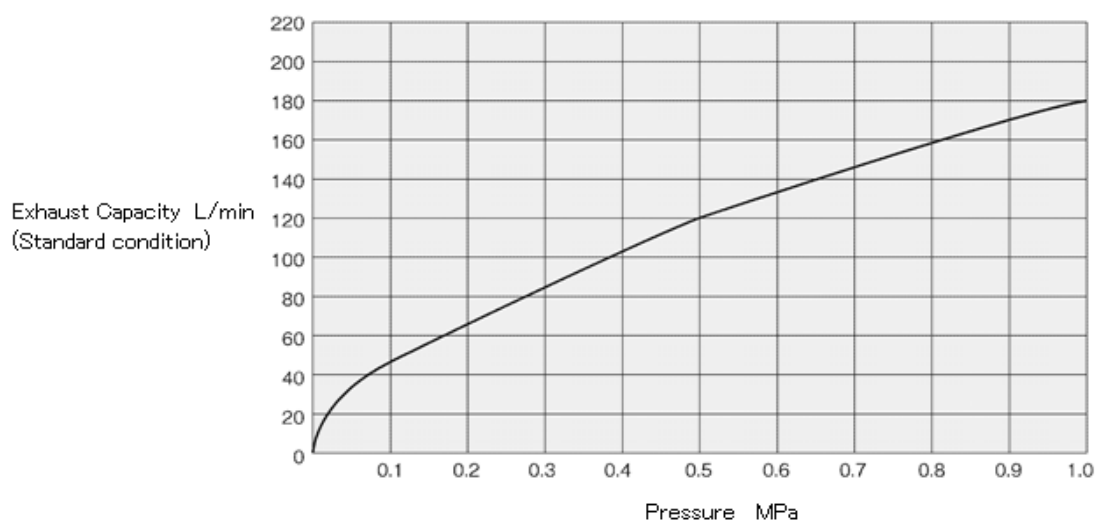

2. Dimensions and Weights

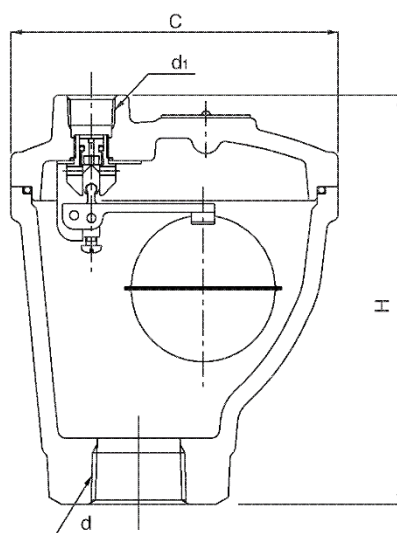

(mm)

Nominal size	d	d ₁	H	C	※ Weight (kg)
15A	Rc 1/2	Rc 3/8	139	114	2.85
20A	Rc 3/4	Rc 3/8	139	114	2.85
25A	Rc 1	Rc 3/8	143	114	3.00
32A	Rc 1 1/4	Rc 3/8	143	114	3.00

※The above weights refer to those of TA-3C and TA-3C-N.

3. Operation

- (1) When installation, the float is in the lowered position and the valve seat is in opened position.
- (2) When water flows into the valve, pipe air is exhausted out of the valve seat being pushed by water.
- (3) The float is pushed up floating by water flowed into, and the valve connected with the float is closed.
- (4) With air coming into, the float is lowered immediately, and at the same time the valve is lowered, and therefore the air is exhausted out of the valve seat.

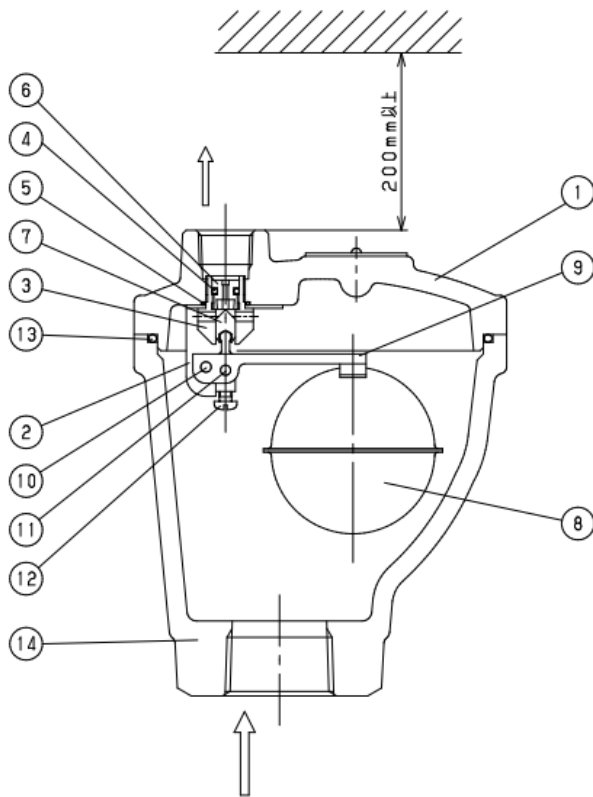

No.	Parts
1	Cover
2	Hanger
3	Valve guide
4	O-ring
5	O-ring
6	Valve seat
7	Valve
8	Float
9	Arm
10	Pin
11	Pin
12	Cross recessed pan head machine screw
13	O-ring
14	Body

4. Maintenance and inspection

4.1 Caution before usage

Caution

- (1) For brass parts, corrosion is generated or accelerated by water quality, and leads to malfunction of the product. For surroundings where corrosion can be generated, please select the product with enduring parts such as stainless steel material.
- (2) If component having negative effect on inner parts is included in fluid and surroundings, deterioration of rubber parts is accelerated and causes outside leakage and functional disorder.
- (3) Impact by rapid pressure change, such as water hammer, breaks the product or parts.
- (4) If fluid cannot flow due to piping situation of the product, fluid temperature rise expands volume of fluid in the piping and damages the product.
- (5) Fluid with viscosity fixes the parts and leads to malfunction of the product.
- (6) Do not disassemble the product unnecessarily.
* If you disassemble the product unnecessarily, the function of the product will not be fulfilled.
- (7) Clean the product thoroughly so as not to leave dirt, foreign matter, oils such as cutting oil, solvents, chemicals inside the pipe before installing the product.
* If the inside of the piping is insufficiently cleaned, problems may occur in the product, leading to leakage.
- (8) Install the product to the place where air is easy to accumulate, upright within 5 degree angle to the vertical. * The function of the product is not fulfilled.
- (9) Be sure to remove foreign matter, scales, etc. In piping when piping the product. Also, please make sure that the sealing tape, liquid sealant etc. used for piping connection do not enter the pipe. Contamination of foreign matter, scale, sealant, etc. will cause malfunction etc.
- (10) For installation on piping, please tighten the hexagonal part of the main body with a wrench or the like. Do not tighten more than necessary. * The main body may be deformed, causing malfunction.
- (11) In case of water leakage, please piping the outlet side to the drain groove.
Make indirect drainage so that the tip of this pipe does not submerge.
- (12) Make piping so that excessive load, bending, vibration etc. are not transmitted to the product.
- (13) Install and check the attitude of the doorway.
*If you mistake the installation, the function of the product will not be fulfilled.
- (14) Do not make dissimilar metal piping which causes difference of electrical potential. If not, the product and parts are corroded.
- (15) Do not ground the product and piping. It may cause corrosion.
- (16) Prevent fluid from freezing.
(When using it in a place where there is a fear of freezing, please take appropriate measures such as heat insulation, heating, draining). * The function of the product may be impaired.

- (1) Install it in places where maintenance, inspection and repair are easy. Place the outlet side piping so that it is 200 mm higher than the outlet top of the product.
- (2) Install it to a place not subject to abnormal high pressure by water hammer etc.
- (3) Select products with considering usage conditions (usage frequency and durability).
- (4) Install a stop valve (cock or gate valve) to the inlet of air release valve for maintenance and inspection. Do not use globe valve. In case of leakage due to foreign substance stuck, close the stop valve immediately.
- (5) Conduct inspections to maintain product function and performance.

Inspection: Make sure that air is normally discharged from the outlet side and that there is no external leakage.

* If there is an abnormality, ask a specialized dealer for treatment.

- (6) For prevention of water leakage just in case, lead the outlet to drain ditch. Make head of this piping as indirect water discharge to prevent submerging.

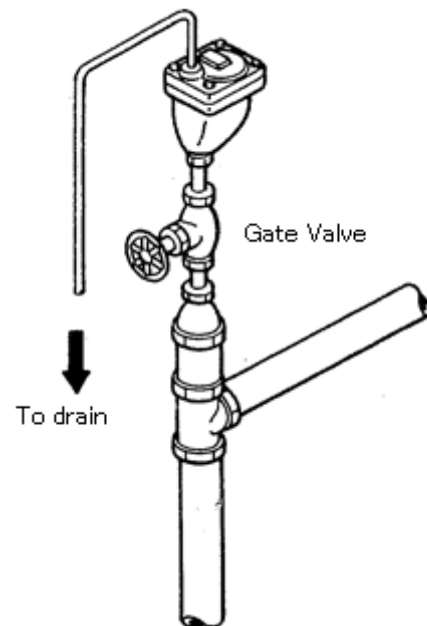

4.2 Warning during the operation

⚠ Warning
<p>(1) In case of high temperature fluid, do not touch the product directly with bare hands.</p> <p style="padding-left: 20px;">* There is a danger of burning.</p> <p>(2) When flowing the fluid, slowly open the fluid supply valve so that water hammer does not occur.</p> <p style="padding-left: 20px;">* If the fluid supply speed is too high, the product will be damaged by water hammer.</p>

⚠ Caution
<p>(1) If fluid is held in the product for a long period of time, the sliding parts will stick and cause malfunction.</p> <p>(2) If you have been suspended for a long time, please conduct inspection before restarting.</p> <p style="padding-left: 20px;">※ If there is an abnormality, please ask a specialized dealer for treatment.</p> <p>(3) Do not use outside the applicable pressure range or exceed the maximum service temperature.</p> <p style="padding-left: 20px;">※ It may cause breakage of the product or exhaust failure.</p> <p>(4) Check the connections and other parts during trial operation and check that there are no leaks.</p> <p>(5) During evacuation, water may blow out like a mist, but it is not a malfunction.</p> <p>(6) When the temperature is low during the winter season or when water is not used for a long time, always drain operation is performed.</p>

4.3 Troubleshooting

Trouble	Causes	Remedy
Air cannot be exhausted	<ol style="list-style-type: none"> 1. Stop valve at inlet side is closed. 2. Piping pressure is above the optimum level. 	<ol style="list-style-type: none"> 1. Fully open the stop valve. 2. Reduce the piping pressure, or replace the valve by the type for high pressure.
Water is blown off	<ol style="list-style-type: none"> 1. Valve P and valve seat are bitten by foreign substance. 2. Valve P and float P are damaged. 3. Valve seat is damaged. 	<ol style="list-style-type: none"> 1. Disassemble and clean the valve P and valve seat. 2. Replace the complete float. 3. Replace the product

- Most of product failures are due to scales such as sand and dust in the pipeline. Pay attention to dust in piping enough.
- If the necessity of replacing damaged parts cannot be decided, contact us.

5. Disassembly

5.1 Precautions during disassembly and inspection

Warning

- (1) Conduct disassembly and inspection by skilled professional person or manufacturer.
 - (2) Be sure to discharge all internal pressure before disassembly and inspection of the valve. And, in case high temperature application, be sure to be cooled down the valve before disassembly and inspection.
- ※Failure to do so may result in injury or burns due to residual pressure or spillage around the valve.

Caution

- (1) If trouble is due to the cause of the failure other than the contents described in "4.Troubleshooting", contact us.
- (2) On disassembly, since fluid inside flows out, receive it with a container.
- (3) O ring is a consumable item. It varies greatly depending on usage conditions, but the guideline period for replacement is 5 years.

5.2 Disassembly procedure

* Before disassembly, stop drive of heat source (hot water boiler, electric water heater, etc) and pump. Discharge pressure inside valve and piping, and confirm that remaining pressure is zero.

- (1) Remove the cover clamping bolt (M10).
- (2) Remove the O ring (G-100).
- (3) Remove the pin for fixing the float, and remove the complete float.

5.3 Assembly procedure

Assembly can be done in reverse order of disassembly.

5.4 Caution for assembly

(1) Confirm that there are no foreign substances such as foreign matters inside the main body and each part.

* If there is foreign object, the original performance will not be utilized.

(2) Check that there are no scratches on the valve body, valve seat and O ring.

* If there are scratches, the original performance will not be utilized.

(3) Apply silicone grease to O ring.

* If silicone grease is not applied, O ring may be damaged.

6. Exploded drawing

*For TA-3C, TA-3C-N, a flat washer is inserted into hexagonal head screw.

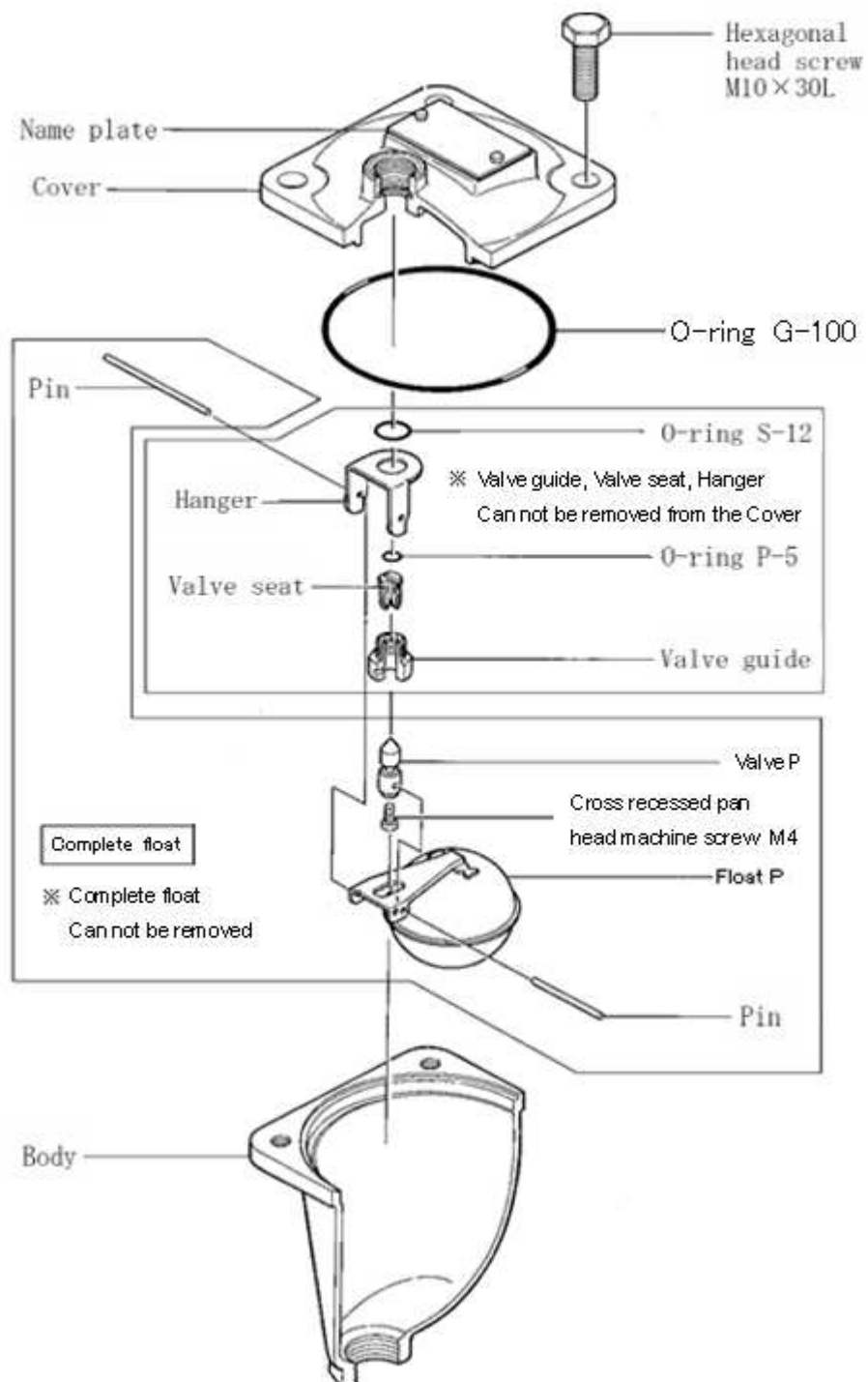

*Please disassemble the product after completely withdrawing the internal pressure.