

# TRAP STAR™ MODEL TSF-10CF STEAM TRAP

## PRODUCT MANUAL

Thank you very much for choosing the Yoshitake's product. To ensure the correct and safe use of the product, please read this manual before use. This manual shall be kept with care for future references.

Please download the English instruction manual for this product from "https://www.yoshitake-inc.com".

本製品の取扱説明書は、「https://www.yoshitake.co.jp」からダウンロードできます。

本产品的中文安装使用说明书请从以下网址下载。' https://www.yoshitake-inc.com/cn'

ถ้าต้องการ ดาวน์โหลดคู่มือของผลิตภัณฑ์ ภาษาไทยให้ ดาวน์โหลดได้ที่ "https://www.yoshitake-inc.com/th"



English



日本語





汉语



ภาษาไทย

The symbols used in this manual have the following meanings.

	<b>Warning</b>	This symbol indicates a potentially hazardous situation that, if not avoided, could result in death or serious injury.
	<b>Caution</b>	This symbol indicates a hazardous situation that, if not avoided, may result in minor or moderate injury or may result in only property damage.

### Table of Contents

1. Specifications.....	1
2. Dimensions and Weights .....	2
3. Operation .....	3
4. Maximum Continuous Discharge Capacity.....	4
5. Installation .....	5
5.1 Piping example.....	5
5.2 Precaution for installation.....	7
6. Operating Procedure .....	10
6.1 Precaution for operating procedure .....	10
7. Maintenance.....	11
7.1 Precaution for maintenance.....	11
7.2 Daily and periodic inspections.....	12
7.3 Troubleshooting.....	13
7.4 Exploded drawing .....	14
7.5 Disassembly .....	15
7.6 Reassembly.....	17
7.7 Parts replacement procedure.....	20
8. Disposal .....	20

Warranty Information

# YOSHITAKE

## 1. Specifications

Model		TSF-10CF
Nominal size		15A,20A,25A
Application		Steam condensate
Working pressure (Maximum working differential pressure)		TSF-10CF-5: 0.01-0.5 MPa (0.5 MPa) TSF-10CF-10: 0.01-1.0 MPa (1.0 MPa) TSF-10CF-21: 0.01-2.1 MPa (2.1 MPa)
Max. temperature		220°C
Material	Body	Cast carbon steel
	Float	Stainless steel
	Valve, valve seat	Stainless steel
Connection		ASME 150LB
		ASME 300LB
		EN PN 25/40
Flow direction		All directions *

\* For installation posture, see Caution No. 4, "5.2 Precaution for installation" on Page 8.



### Caution

Please confirm that the indications on the product correspond with the specifications of the ordered product model before use.

\* If they are different, do not use the product and contact us.

## 2. Dimensions and Weights

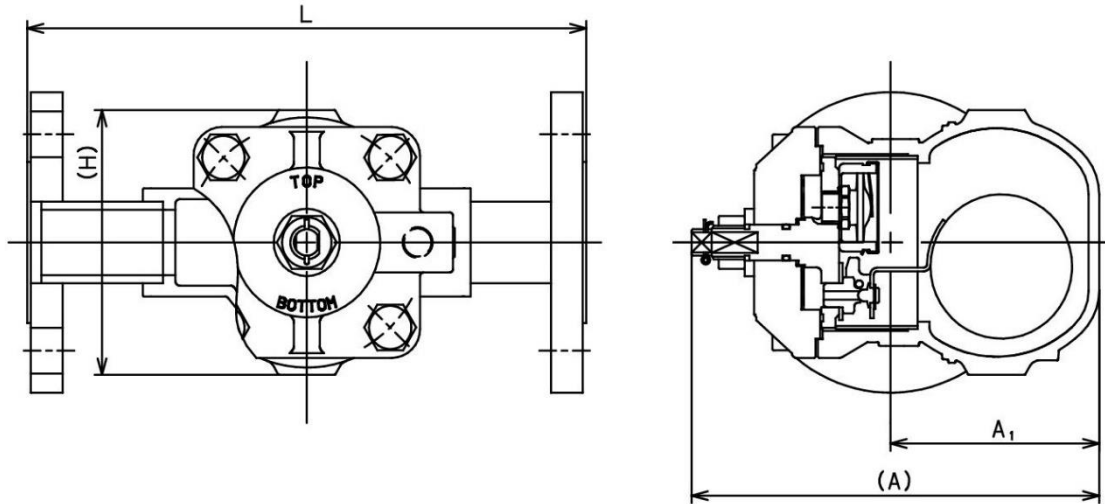

(mm)

Nominal size	L	A	A <sub>1</sub>	H	Weight (kg)		
					ASME150LB	ASME300LB	EN PN25/40
15A	195	173	88.5	110	4.8	5.0	5.0
20A	215	173	88.5	110	5.2	5.4	5.4
25A	235	173	88.5	110	6.2	6.6	6.6

### 3. Operation

#### 1. Start-up of the operation

At start-up, since the float is down, the valve is closed. In this state, air in the system and piping is discharged out through the air vent which is opened. When condensate flows into the product, the float lifts up and opens the valve, and then discharges condensate. Air is continuously discharged out from the air vent.

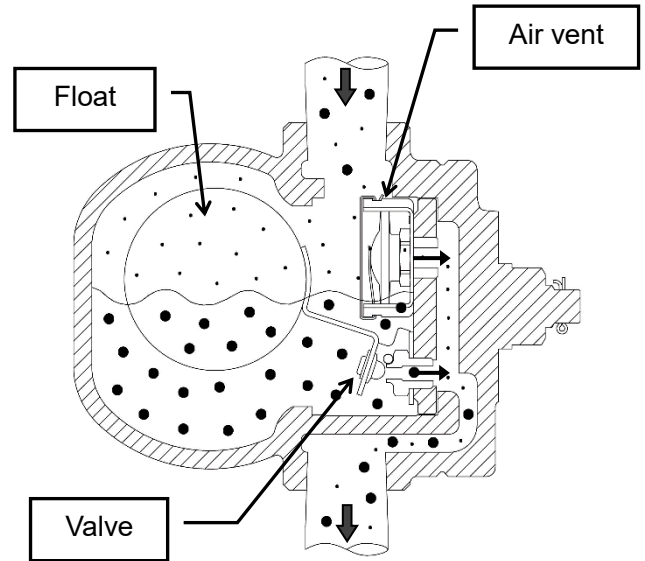

#### 2. Condensate discharging operation

When steam flows into the product, internal pressure of the air vent rises by steam temperature, and the air vent closes. According to the amount of condensate inflow, the float position moves up and down changing the opening degree of the valve, and thus condensate is continuously discharged. The float moves down and the valve closes when condensate inflow stops.

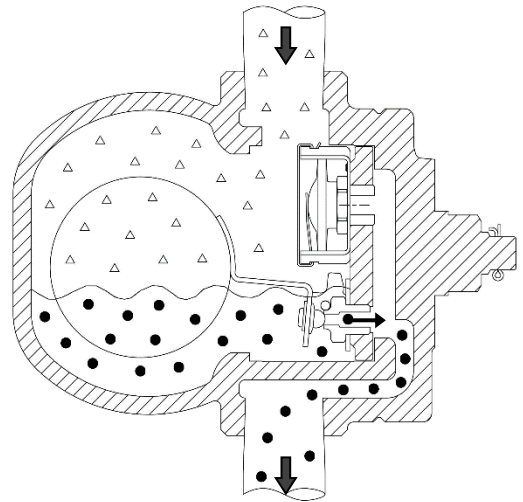

#### 3. Air vent operation

When air or non-condensable gas flows into the product, it accumulates in the upper part of the product. When temperature of air or non-condensable gas decreases with condensate inflow, the air vent opens and discharges it to outside of the product.

Then, operations 2 and 3 repeats according to the inflow amount of condensate and air.

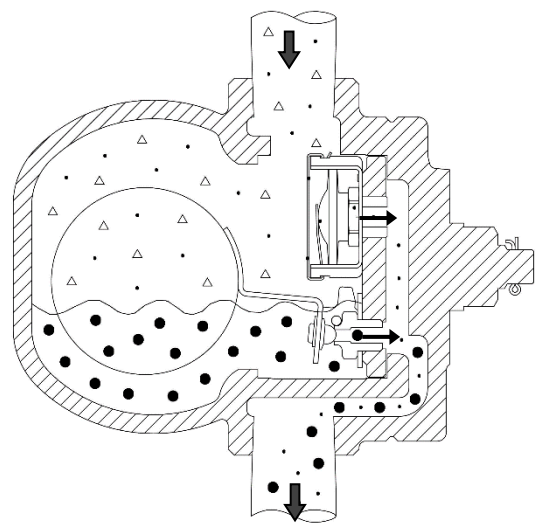

Condensate



Steam



Air

---

#### 4. Maximum Continuous Discharge Capacity

---

1. Discharging capability of the steam trap differs by working differential pressure, that is, difference between inlet pressure and outlet pressure (back pressure). In selecting discharge capacity, consider outlet pressure. If inlet pressure is 0.5 MPa and outlet pressure is 0.2 MPa, discharge capacity is of working differential pressure of 0.3 MPa.
2. The discharge capacity shown in the charts below is the maximum value. In designing a system, select a steam trap with a sufficient safety factor (two times the regular level). That is, for example, if a discharge capacity of 500 kg/h is required, select a steam trap capable of discharging more than 1,000 kg/h (maximum discharge).

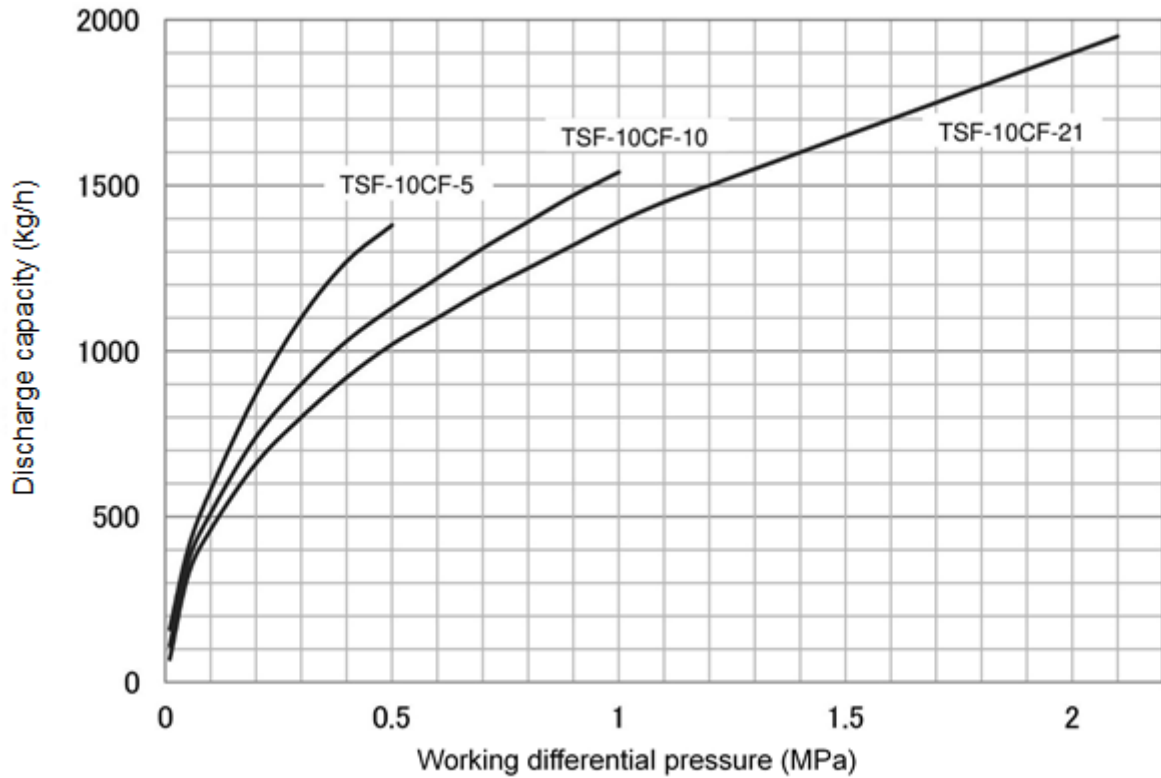

## 5. Installation

### 5.1 Piping example

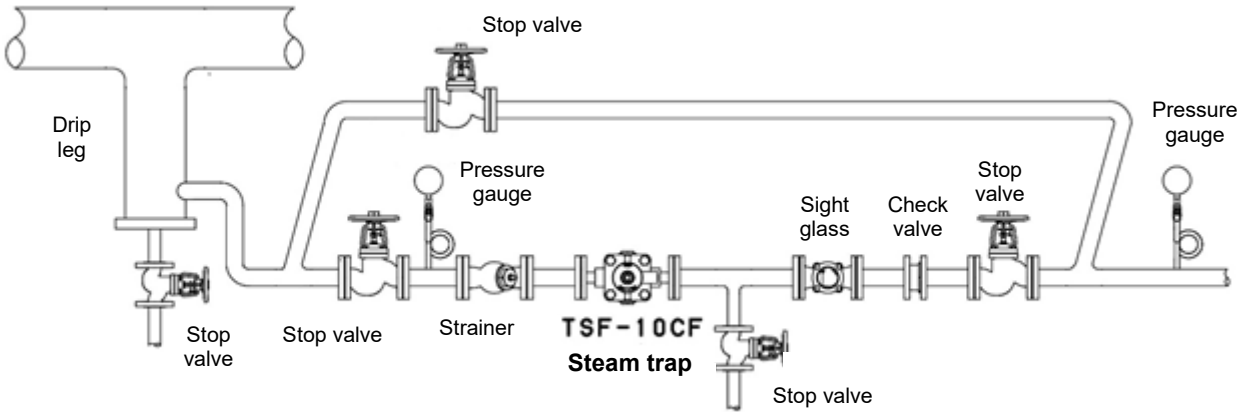

Description	Correct	Incorrect
<p>If the product is installed close to a regulating valve, make sure to install the product at the inlet side of the regulating valve.</p>		
<p>To discharge condensate from the steam main, be sure to install the product so that condensate can be discharged from the bottom of the steam main by drip leg.</p>		

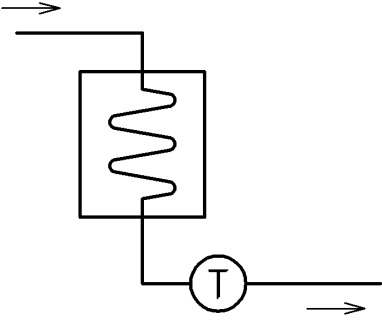
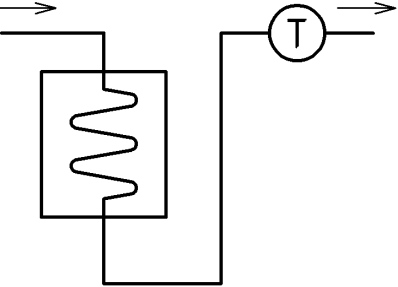
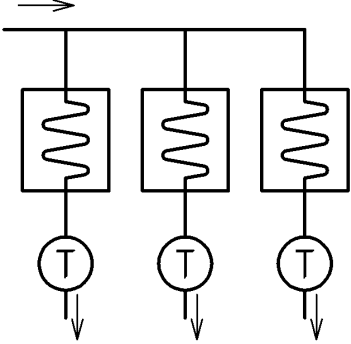
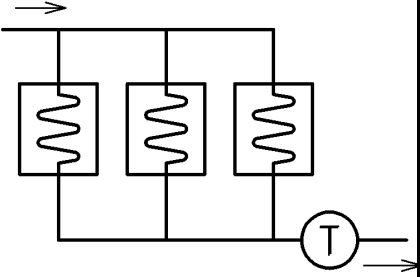
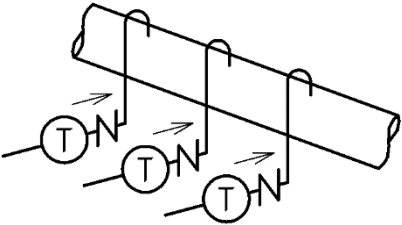
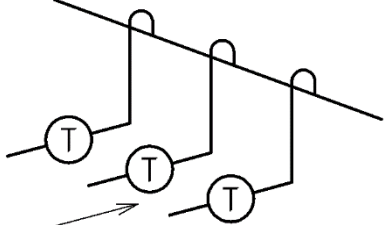
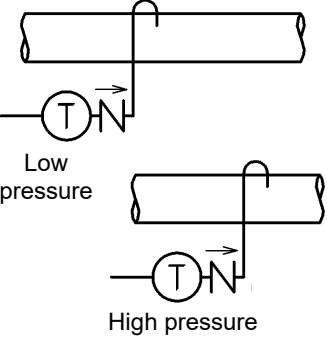
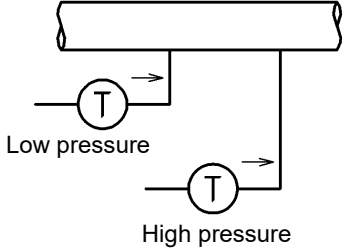
Description	Correct	Incorrect
<p>Install the product below a device which generates condensate.</p>		
<p>Install the products for each device independently.</p>		
<p>The diameter of collecting pipe shall be more than summation of sectional areas of discharge pipes. In addition, install check valves for back flow prevention.</p>		
<p>For condensate recovery, connect the discharge pipe to the upper part of collecting pipe.</p> <p>For traps of different pressure lines, install collecting pipes individually for each pressure. In addition, install check valves for back flow prevention.</p>		 <p>* Re-evaporated steam in high pressure line increases the back pressure of low pressure trap.</p>

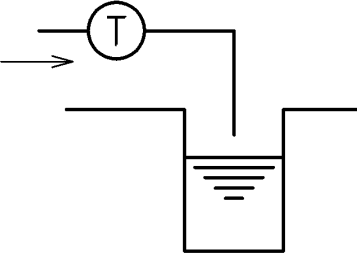
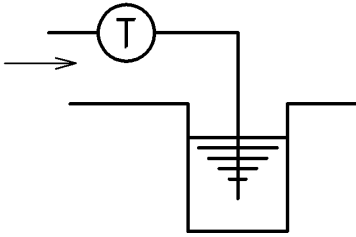
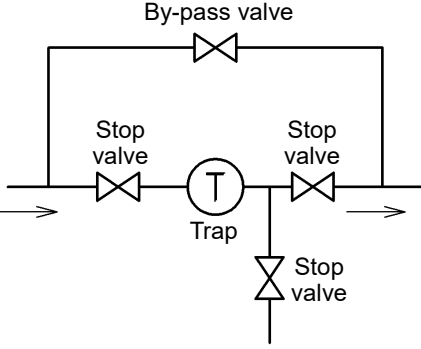
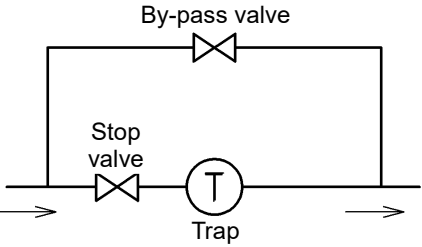
Description	Correct	Incorrect
<p>End portion of discharge pipe shall be off the water surface in the pit.</p>		 <p>* If the discharge pipe is in contact with the water, it absorbs dirty water in the pit and causes malfunction of the product.</p>
<p>Provide a by-pass line around the product, and install stop valves at the outlet side of the product.</p>		

## 5.2 Precaution for installation

 <b>Caution</b>
<ol style="list-style-type: none"> <li>1. Before connecting the product to piping, remove foreign substances and scale from the piping. <ul style="list-style-type: none"> <li>* Failure to follow this notice may prevent the product from functioning properly.</li> <li>* To plumb the product, be careful to keep seal materials from entering into the product.</li> </ul> </li> <li>2. To install the product, check the direction of the product so that the fluid flowing and the arrow marked on the product are in the same direction. <ul style="list-style-type: none"> <li>* Setting the product in wrong directions prevents it from functioning properly.</li> </ul> </li> <li>3. Do not apply excessive load, torque or vibration to the valve. <ul style="list-style-type: none"> <li>* Doing so may result in malfunction or drastically shortened service life.</li> </ul> </li> </ol>



**4. Check installation posture.**

\* Wrong posture hampers proper operation.

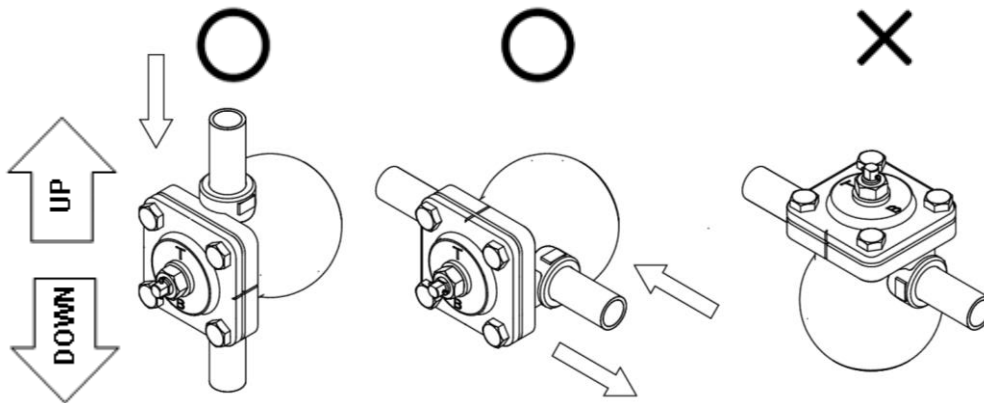

\* Allowable tilt from horizontal line is within  $\pm 10^\circ$ .

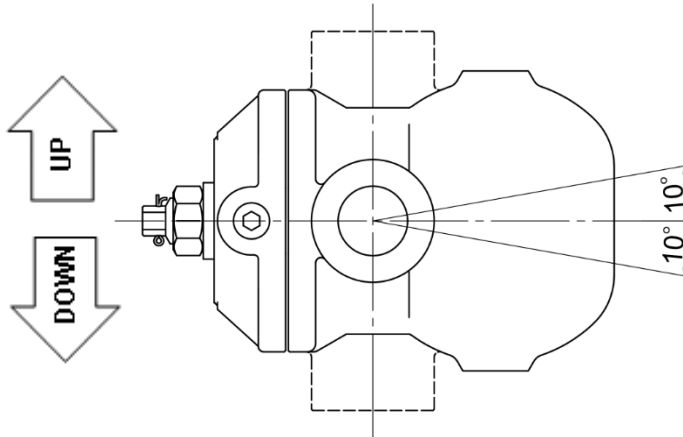

**5. Adjust direction of the name plate in no pressure condition after installation.**

\* Do not turn the cock unless the pressure inside of the product and piping is completely discharged. Forcing the cock to turn may result in damage to the cock.

\* Wrong direction hampers proper operation.

\* Fix the cock with spanner and loosen the nut. Turn the cock and adjust direction of the name plate to position "TOP" and "BOTTOM" signs on upside and downside respectively. Fix the cock with spanner and fasten the nut after adjustment.

\* Allowable tilt from vertical line is within  $\pm 10^\circ$ .

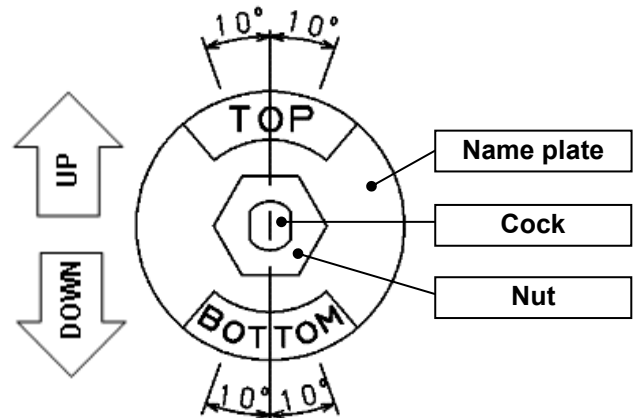

**6. Make sure to support the piping immovably.**

\* If an excessive piping stress is applied, the product may not open or close.

**7. Do not disassemble the product unless it is necessary.**

\* Disassembly may prevent the product from functioning properly.

8. Secure enough space for maintenance (such as cleaning of strainer), inspections and repair as shown below.

\* Failure to follow this notice prevents maintenance, inspection and repair.

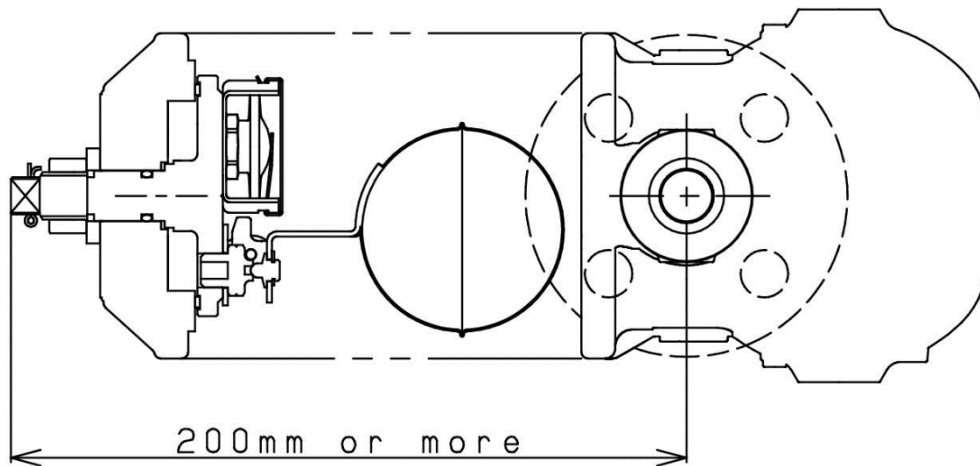

9. Slope the piping and place the product at as a low position as possible in order to make condensate flow into the product by its own weight.

10. To install the product in a main steam pipe, provide a drip leg at the inlet side of the product.

11. Install a strainer (mesh size of 80 or more is recommended) at the inlet side of the product.

12. Install the product so that it is not subjected to the shock of water hammer. Do not install a quick operating valve before and/or after the product.

\* Failure to follow this notice may result in malfunction due to damage to the float, or may result in scalds or injury due to blow off when the product is subjected to an excessive shock and damaged.

13. Install a bypass line.

\* The system has to stop operation while inspection and maintenance of the product if the bypass line is not installed.

---

## 6. Operating Procedure

---

### 6.1 Precaution for operating procedure

#### **Warning**

1. Before leading fluid, make sure that the product is securely connected to piping and that there is no loose.
  - \* Failure to follow this notice may result in scalds or injury due to blow-off.
2. Do not touch the product with bare hands while the product operates.
  - \* Failure to follow this notice may result in scalds.
3. Do not stand in front of the outlet opening of the product while the product operates.
  - \* Failure to follow this notice may result in scalds or injury due to blow-off.

#### **Caution**

1. Slowly open each stop valve to prevent water hammer.
  - \* Opening stop valves quickly may result in damage to other equipments due to hunting or water hammer.
2. Do not turn the cock while the product operates.
  - \* Do not turn the cock unless the pressure inside of the product and piping is completely discharged. Forcing the cock to turn may result in damage to the cock.
  - \* Wrong direction of the cock hampers proper operation.

---

## 7. Maintenance

---

### 7.1 Precaution for maintenance

#### **Warning**

1. Do not touch the product with bare hands.  
\* Failure to follow this notice may result in burns.
2. Completely discharge internal pressure of the product, piping and equipment, and cool down the product prior to disassembly or maintenance.  
\* Failure to follow this notice may result in scalds or injury due to residual pressure.

#### **Caution**

1. Conduct daily inspection in order to maintain the optimal performance of the product.  
\* Failure to follow this notice may prevent the product from functioning properly.  
\* See “7.3 Troubleshooting” on Page 13 if trouble is observed.
2. After leaving the product not operated for a long period, perform inspection before start-up of operation.  
\* Failure to follow this notice may cause malfunction due to rust inside of the product and piping.
3. Put a container under the product at disassembly since condensate may flow out.  
\* Failure to follow this notice may result in making the surroundings dirty.
4. Be careful not to drop the parts at the time of disassembly. The disassembled parts should be placed on soft cloth in order to avoid scratches and damage.  
\* Damage on the parts may cause malfunction and affect the optimal performance.
5. To assemble, connect all the parts securely and tighten the bolts uniformly in diagonal order.  
\* Failure to follow this notice may cause malfunction or outside leakage.
6. When repairing, do not use the parts other than the dedicated parts manufactured by Yoshitake. Do not modify the product.  
\* Failure to follow this notice may cause damage to the product, or may result in scalds or injury due to blow-off or malfunction.
7. In case of problems due to foreign substances or scale, the product needs repair or part replacement. Please contact us for details.  
(Please note that any repair due to foreign substances or scale in the product is subject to a charge even during the warranty period.)

## 7.2 Daily and periodic inspections

Conduct daily and periodic inspections in order to maintain the optimal performance of the product. See "7.3 Troubleshooting" on Page 13 for the remedies if trouble is observed.

- Daily inspection (once a day)

Conduct daily inspection during operation of the product.

Items	Standards for Inspection
Discharge condition of condensate	Condensate is discharged smoothly.
Outside leakage	No outside leakage of condensate or steam.

- Periodic inspection (once a year)

Conduct disassembly inspection periodically.

Items	Standards for Inspection
Seat surfaces of the valve and valve seat	No scratch, abrasion, or foreign substances on seat surfaces.
Shape of float (P)	No deformation or damage on the float (P)
Dirt on the screen	No clogging on the screen

## 7.3 Troubleshooting

Trouble	Cause	Remedy
Condensate is not discharged.	1. Blockage of foreign substances in a discharge hole of the valve seat.	1. Disassemble and clean it.
	2. The screen is clogging.	2. Disassemble and clean it.
	3. The float (P) is damaged.	3. Replace it with a new one.
	4. Breakage as a result of abnormal pressure rising due to freezing or water hammer, etc.	4. Replace the product with new one and use it within the working pressure range.
	5. Steam locking.	5. Change the piping system layout.
	6. "TOP" and "BOTTOM" signs on the name plate are in wrong positions.	6. Adjust direction of the name plate to position "TOP" and "BOTTOM" signs on upside and downside respectively. * See Caution No. 4, "5.2 Precaution for installation" on Page 8.
Continuous blowout.	1. Foreign substances stuck on valve, valve seat or air vent (P).	1. Disassemble and clean them.
	2. Abrasion or scratches on the valve, valve seat or air vent (P).	2. Replace the parts with new ones.
	3. Insufficient capacity of the product.	3. Replace the product with another model of sufficient capacity.
	4. "TOP" and "BOTTOM" signs on the name plate are in wrong positions.	4. Adjust direction of the name plate to position "TOP" and "BOTTOM" signs on upside and downside respectively. * See Caution No. 4, "5.2 Precaution for installation" on Page 8.
Steam leakage.	1. Leakage due to loosening of the bolt.	1. Replace the cover gasket with new one, and retighten the bolt.
	2. Leakage due to deterioration of cock gasket (P2) and O-ring.	2. Replace the parts with new ones.
	3. Leakage as a result of abnormal pressure rising due to freezing or water hammer, etc.	3. Replace the product with new one and use it within the working pressure range.

## 7.4 Exploded drawing

\* The parts shown in the rectangle boxes are available as consumable supply.

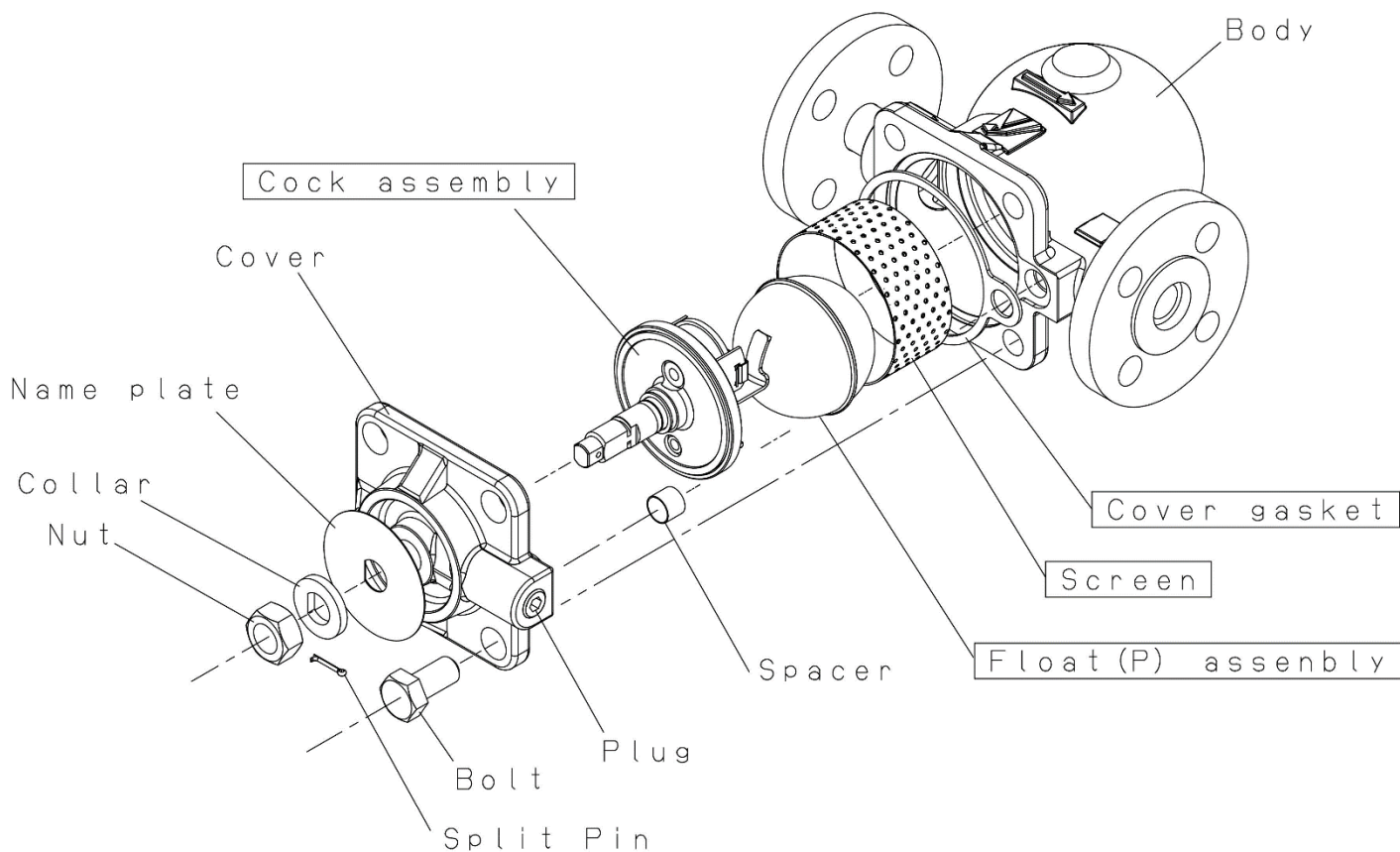

\* Do not remove the plug from the cover except when disposing.

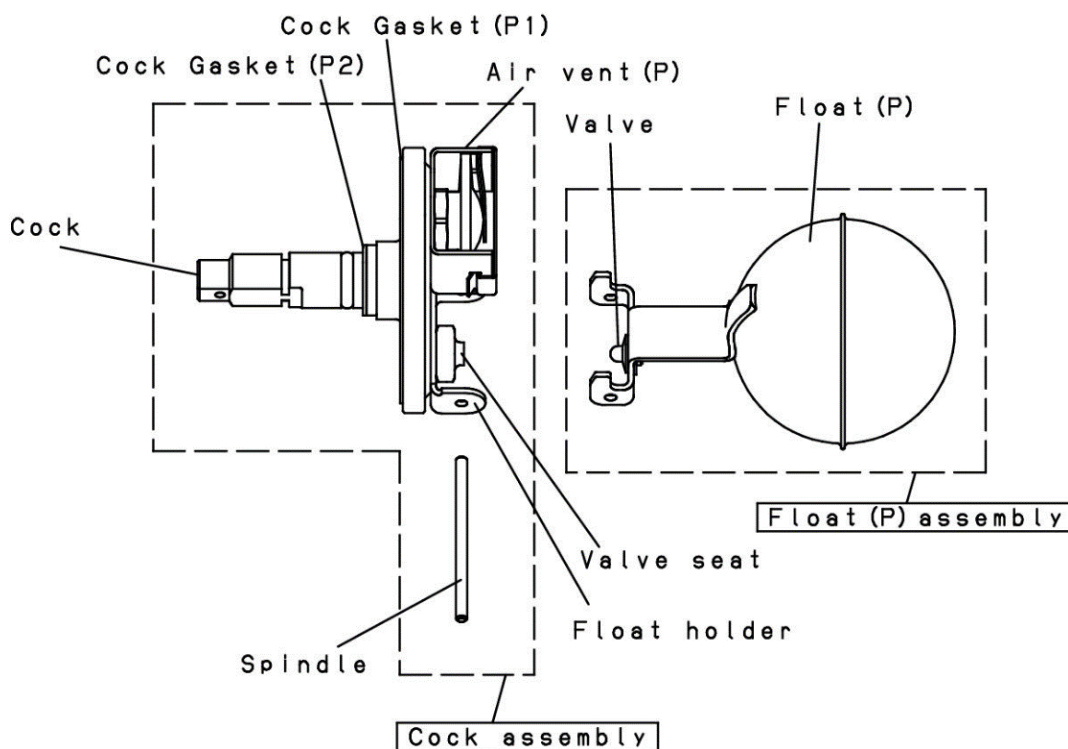

\* The air vent (P) cannot be removed from the cock assembly.

## 7.5 Disassembly

- Tools to be used

Name of tool	Size (Nominal size)
Spanner	22 mm
Ring wrench	19 mm

[Procedure 1] Loosen the bolts fixing the cover with ring wrench (width across flat: 19 mm), and remove the cover and gasket from the body. Pull out the screen from the body.

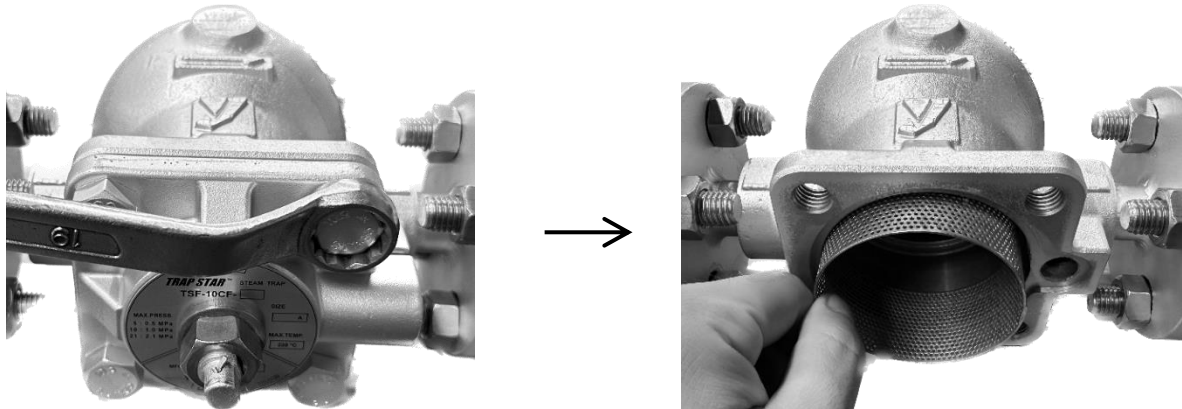



[Procedure 2] Pull out the spindle from the float holder and remove the float (P) assembly.



[Procedure 3] Remove the split pin from the cock. With fixing the cock (width across flat: 9 mm), remove the nut by using spanner (width across flat: 22 mm), and then remove the collar and the name plate.

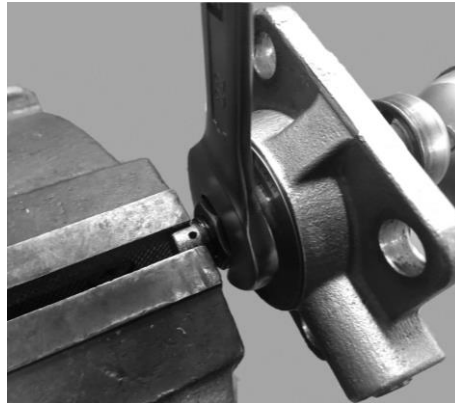

[Procedure 4] By pulling out the cock from the cover, the cock assembly can be replaced.

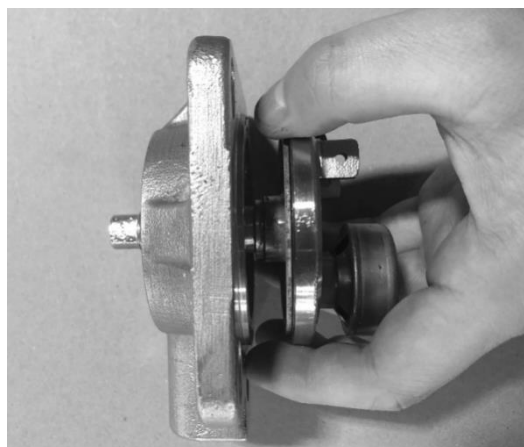

## 7.6 Reassembly

- Tools to be used

Name of tool	Size (Nominal size)
Torque Wrench	* Tightenable with torque of 30 N·m Width across flat: 19 mm
Torque Wrench	* Tightenable with torque of 45 N·m, Open-head type Width across flat: 22 mm
Spanner	9 mm
Ring Wrench	22 mm

[Procedure 1] Check that the cock gasket (P1), plate, cock gasket (P2) and O-ring (P11) are attached to the cock. Apply lubricant agent to the cock gasket (P1) at its contacting surface with the cock (Recommendation: SOLVEST No.110 paste, STT Inc.). Apply fluoro grease to the O-ring (Recommendation: SOLVEST No.245, STT Inc.).

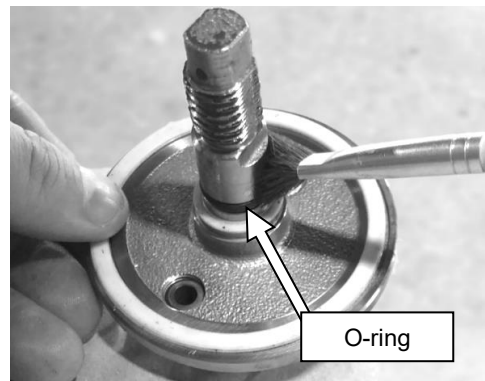
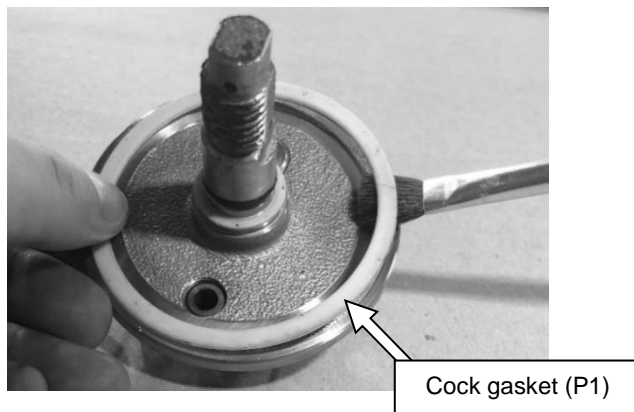

[Procedure 2] Attach the cock (after taking Procedure 1) to the cover. Check that the cock gasket (P1) is attached to the cock properly. If not, it may cause steam leakage to the outlet side.

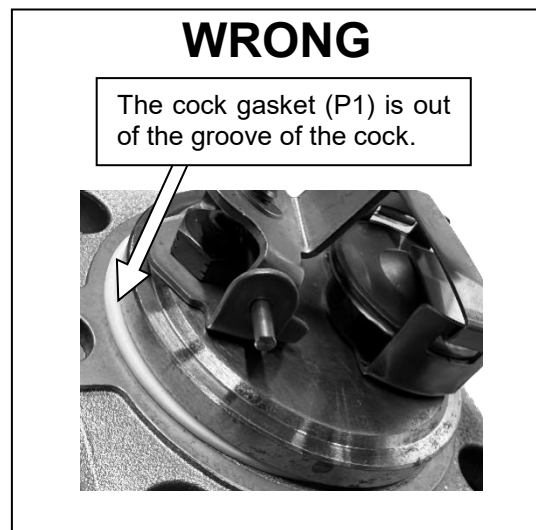
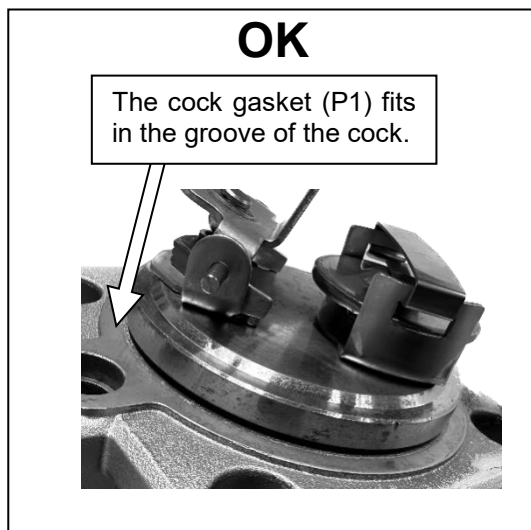

- [Procedure 3] Attach the name plate, collar, and nut to the cock.  
 \* When installing, match the holes on the name plate and collar with shape of the cock.

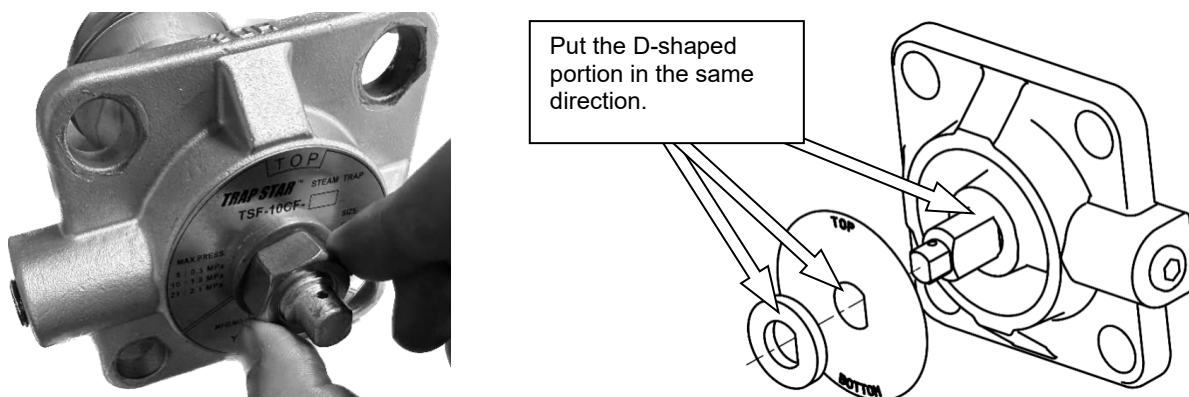

- [Procedure 4] Connect the float holder and float (P) assembly with the spindle. Check that the float (P) assembly moves smoothly, and that the seat surface of the valve is in contact with that of the valve seat.

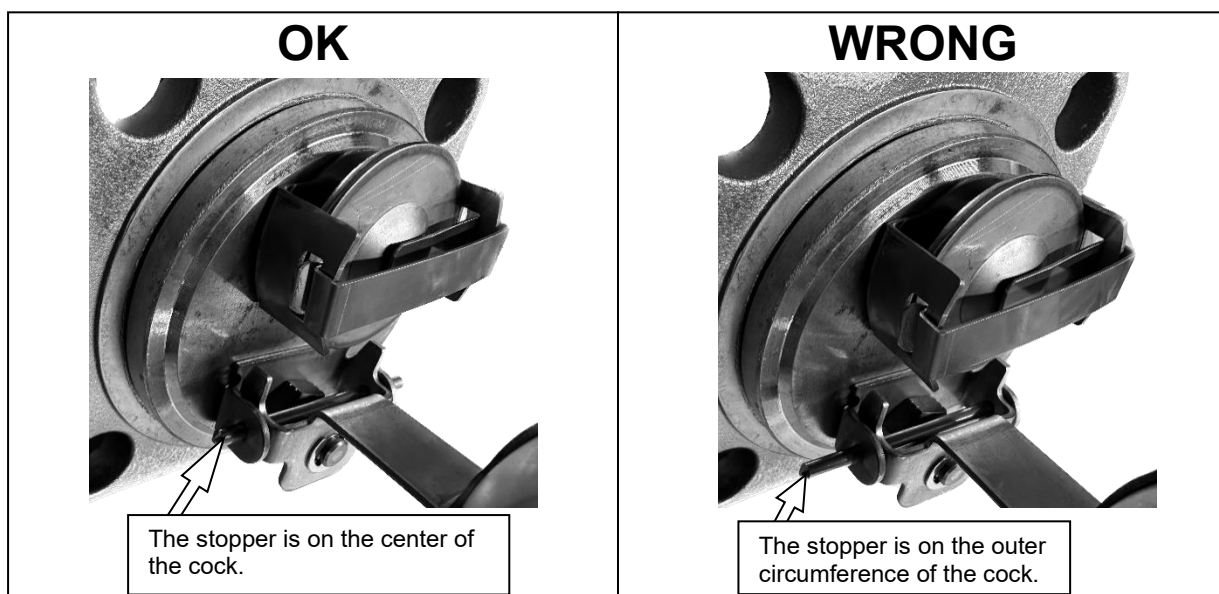

- [Procedure 5] Attach the screen to the body. The screen can be inserted from either end.



[Procedure 6]

Install the cover gasket to the cover. Adjust the round hole positions of the cover and the cover gasket, and insert the spacer to the round hole. Make sure to use a new cover gasket. Apply lubricant agent to the cover gasket (Recommendation: SOLVEST No.110 paste, STT Inc.)

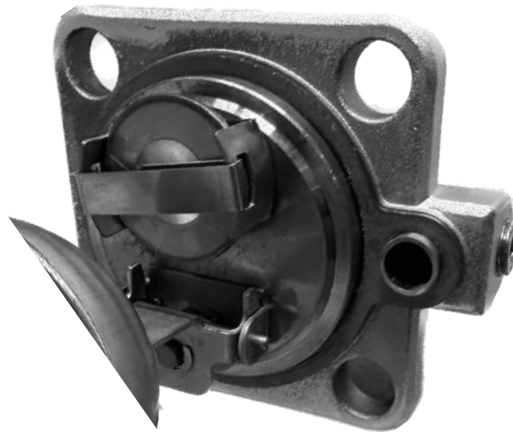

[Procedure 7]

Install the cover to the body, making the round holes on the cover and on the body in the same position.

Tighten the bolt with torque wrench (width across flat: 19 mm) with torque of 30 N·m.

\* Do not use impact wrench to tighten the bolt. Using it may cause unevenly tightened bolt or damaged gasket, resulting in outside leakage of condensate or steam.

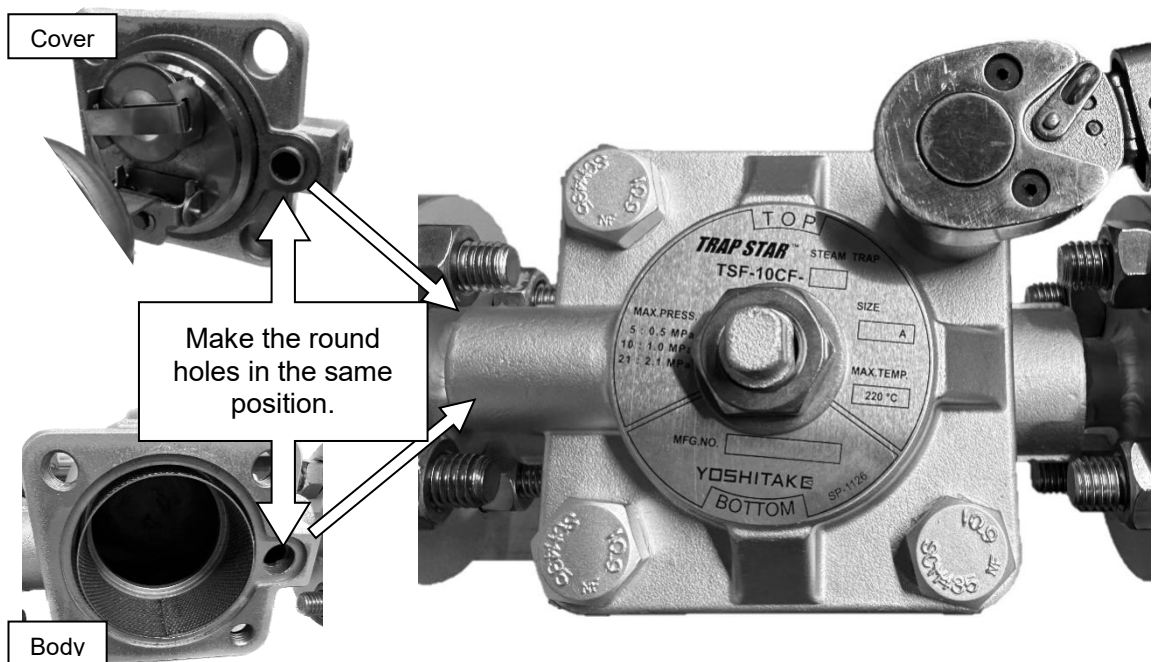

[Procedure 8]

With applying spanner to the cock (width across flat: 9 mm), adjust the direction of the name plate. After adjustment, tighten the nut with torque wrench (width across flat: 22 mm) with torque of 45 N·m.

\* If the name plate is not in correct direction, the product does not work properly. See Caution No. 4, "5.2 Precaution for installation" on Page 8 for the adjustment procedure.

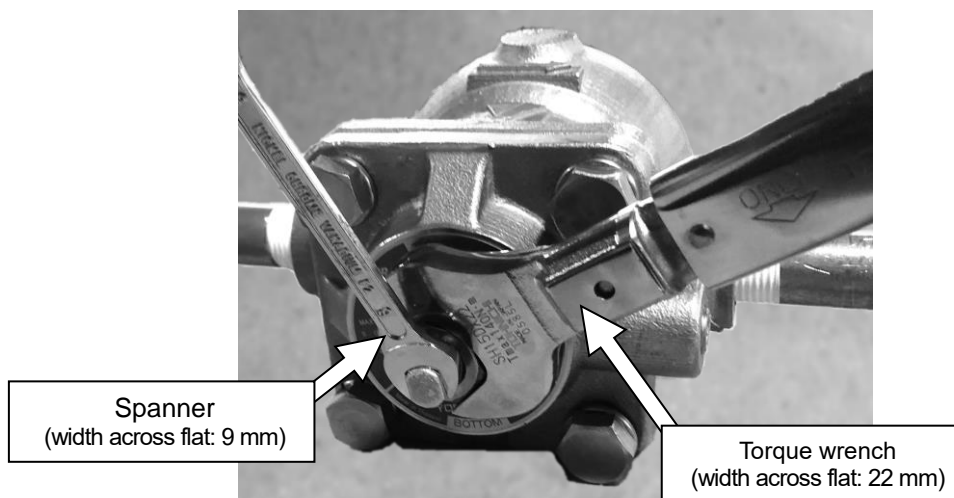

## 7.7 Parts replacement procedure

Part name	Disassembly (See 7.5.)	Reassembly (See 7.6.)
Cover gasket	Procedure 1	Procedures 6 to 7
Float (P) assembly	Procedures 1 to 2	Procedures 4 to 7
Cock assembly	Procedures 1 to 4	Procedures 1 to 8
Screen	Procedure 1	Procedures 5 to 7

## 8. Disposal

When disposing the product, refer to the drawing to check material of each part and dispose them separately according to local rules and regulations.

---

## Warranty Information

---

1. Limited warranty

This product has been manufactured using highly-advanced techniques and subjected to strict quality control. Please be sure to use the product in accordance with instructions on the manual and the label attached to it.

Yoshitake warrants the product to be free from any defects in material and workmanship under normal usage for a period of one year from the date of receipt by the original user, but no longer than 24 months from the date of shipment from Yoshitake's factory.

2. Parts supply after product discontinuation

This product may be subject to discontinuation or change for improvement without any prior notice. After the discontinuation of the product, Yoshitake supplies the repair parts for 5 years otherwise individually agreed.

3. This warranty does not cover the damage due to any of below:

- (1) Valve seat leakage or malfunction caused by foreign substances inside piping.
- (2) Improper handling or misuse.
- (3) Improper supply conditions such as abnormal water pressure/quality.
- (4) Water scale or freezing.
- (5) Trouble with power/air supply.
- (6) Any alteration made by other than Yoshitake.
- (7) Use under severe conditions deviating from the design specifications (e.g. in case of corrosion due to outdoor use).
- (8) Fire, flood, earthquake, thunder and other natural disasters.
- (9) Consumable parts such as O-ring, gasket, diaphragm and etc.

Yoshitake is not liable for any damage or loss caused by malfunction or defect of the product.

**YOSHITAKE** 